

# Complete range on PCD turning inserts



PCD  
TURNING

NEW

DIATURN  
PCD  
RANGE

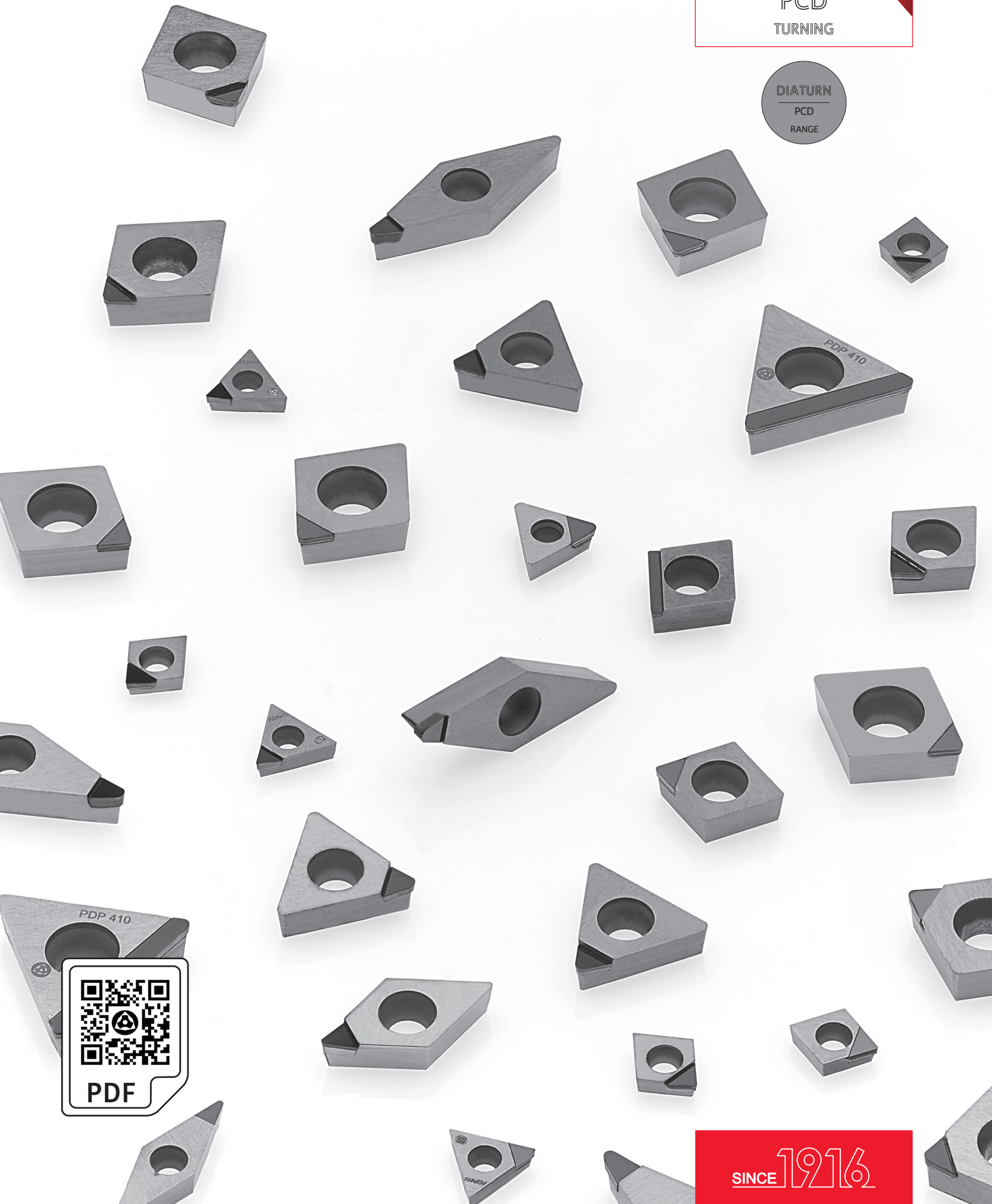

SINCE 1916

# PCD GRADES SELECTION

Seleção de graus | Selección de calidades

PCD (Polycrystalline Diamond) is a composite of diamond particles that are sintered with a metallic binder creating the hardest and one of the most abrasion resistant materials used in cutting tools.

Its development achieved an extremely significance for the machining of Non-Ferrous Materials, such as high-silicon aluminium, metal matrix composites (MMC) and carbon fibre reinforced plastics (CFRP).

## Grade description:

Grade	Code	Characteristics	Application
PDP410	D6	General purpose Fine surface finishing	<ul style="list-style-type: none"> <li>- &lt;14% silicon aluminium alloy - automotive industry</li> <li>- Graphite and graphite composites</li> <li>- Wood composites</li> <li>- Green ceramics</li> <li>- Copper alloy</li> </ul>
PDP403	I3	Highest abrasion resistance Bimodal grain structure for increased diamond percentage content	<ul style="list-style-type: none"> <li>- &gt;14% silicon aluminium alloy</li> <li>- Fiber glass, fiberboard</li> <li>- Wood laminates</li> <li>- Metal matrix composites</li> <li>- Stone sawing</li> <li>- Sintered tungsten carbide (10-16% Co)</li> </ul>

PDP410

<14% silicon  
aluminium  
alloy

PDP403

>14% silicon  
aluminium  
alloy

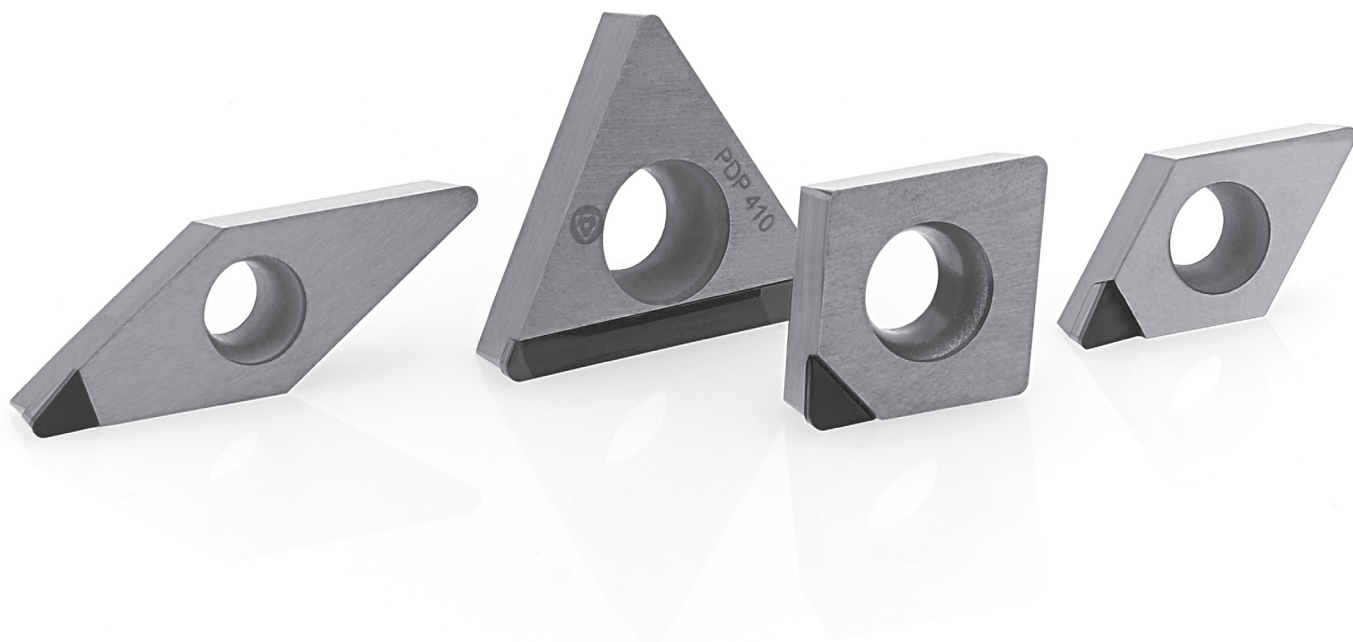

The insert geometry and nose radius are very important on turning operation having direct influence on the tool life and productivity.

**Insert nose radius is an important performance parameter:**

- For good chip breaking, must be used a small nose radius: 0,2-0,4mm (0,008-0,016inch);
- A large nose radius: 0,8-1,2mm (0,031-0,047inch) generates better surface finishing and produces thinner chips, which reduces the degree of crater wear in hard part turning operations
- The machining with large nose radius and small depth of cut results in reduced entry and exit forces..

In general, a large nose radius provides greater edge strength and therefore extended tool life. For this reason, it is advised to use the largest and allowed nose radius based on each process requirements.

**Finishing and semi-finishing:**

In these cases, there are special requirements on the surface and tolerances.

**Roughing:**

For the evaluation of the cutting edge radius in roughing operation it is recommended to use the following formula in order to calculate the minimum radius vs feed:

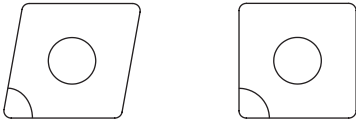
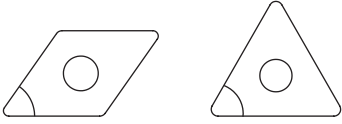
Insert shape	Formula
	<p>Radius &gt;1,6 x feed per rev.</p>
	<p>Radius &gt;2,5 x feed per rev.</p>

# EDGE PREPARATION SELECTION

Seleção da preparação de aresta | Selección de la preparación de arista

The most important criteria for the stability and cutting edge tool-life is to define the correct cutting edge preparation. Its choice is mainly required in order to achieve the best economical result.

## Edge preparation:

PCD: F type cutting edge preparation:

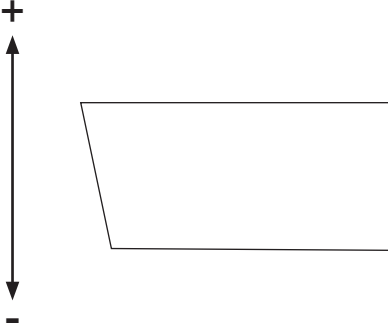
<p>Cutting forces Edge strength</p> 	<p><b>F – Standard preparation without honing - Standard</b></p> <ul style="list-style-type: none"><li>- Sharp cutting edge;</li><li>- Standard and recommended edge preparation for aluminium or other non-ferrous materials.</li></ul>
---	--

## Note:

Based on our experience sometimes is necessary to define edge preparation during several tests to provide the best possible solution for each application.

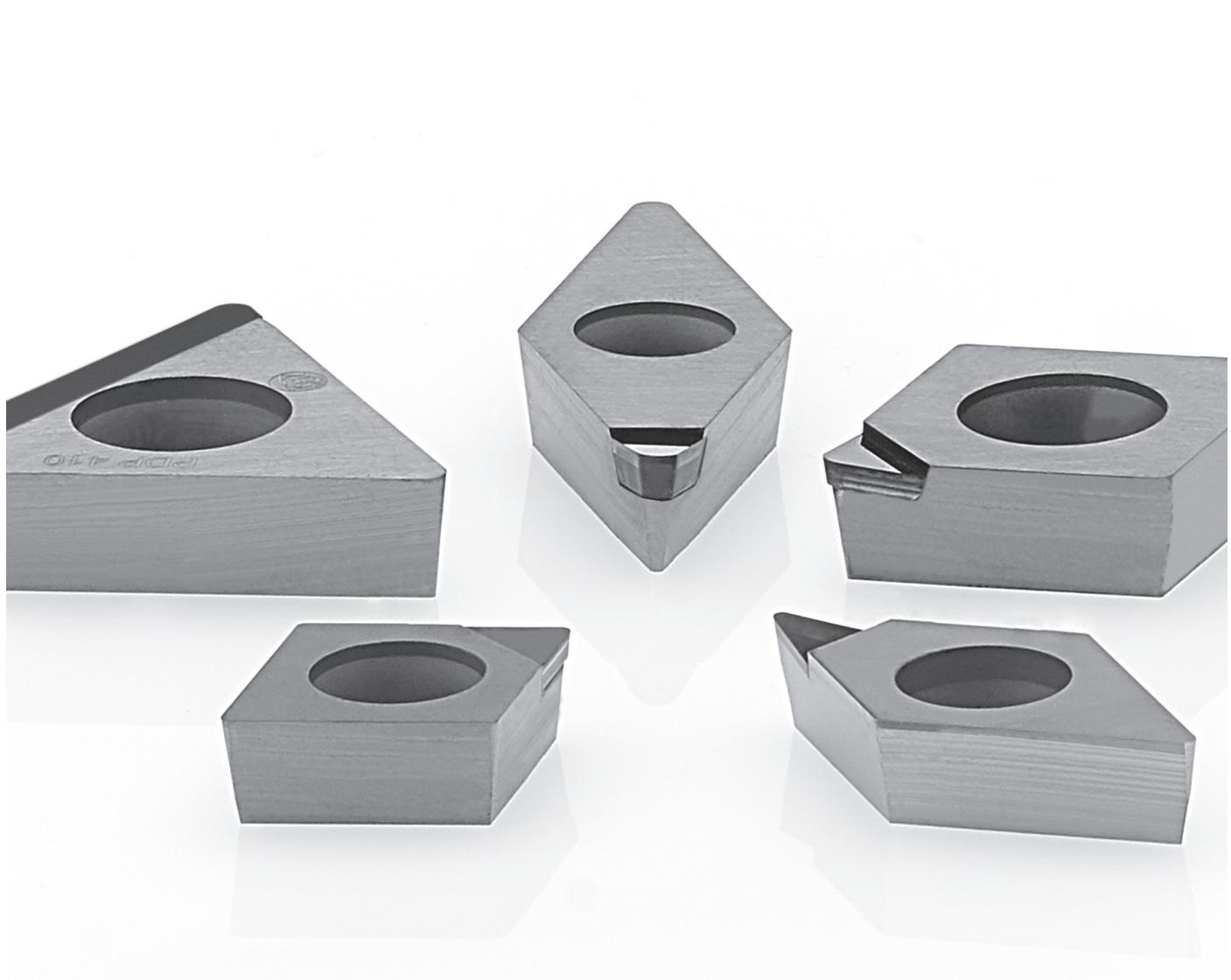

# PCD RECOMMENDED CUTTING DATA



Condições de corte recomendadas para PCD | Datos de corte recomendadas para PCD

Workpiece material	VC (m/min)		Recommend grade for PCD	
			PDP 410	PDP 403
<b>Aluminium alloys:</b> Aluminium, Si<14%	Roughing	800-3000	⊗	
	Finishing	800-3000	⊗	
<b>Aluminium:</b> Aluminium, Si≥14%	Roughing	300-700	○	⊗
	Finishing	250-700	○	⊗
<b>Copper alloys:</b> Copper, Zinc, Brass	Roughing	600-1200	⊗	
	Finishing	700-1500	⊗	
<b>Metal matrix composites:</b> Al (10-20%) SiC	Roughing	300-1150		⊗
	Finishing	400-1260		⊗
<b>Tungsten carbide 10-16% Co:</b> Unsintered	Roughing	50-200		⊗
	Finishing	60-220		⊗
<b>Tungsten carbide 10-16% Co:</b> Sintered	Roughing	20-40		⊗
	Finishing	25-45		⊗
Ebonite, Fiberglass, Plastic materials, Graphite, Glass.	Roughing	200-1500	⊗	⊗
	Finishing	300-2000	⊗	⊗
<b>Ceramic:</b> Unsintered	Roughing	50-150		⊗
	Finishing	50-200		⊗
<b>Ceramic:</b> Sintered	Roughing	20-35		⊗
	Finishing	20-40		⊗
<b>Wood</b>	Finishing	1000-4000	⊗	

⊗ Recommended ○ Second choice

PCD

Code key

Overview

Negative inserts

Positive inserts

Toric Mills

Tailor-made

# ISO PCD INSERTS CODE KEY

H		M	
O		V	
P		W	
S		L	
T		A	
C		B	
D		K	
E		R	
F		X	Special

1- Insert shape symbol

Symbol	m (mm)	d (mm)	s (mm)
A	±0.005	±0.025	±0.025
F	±0.005	±0.013	±0.025
C	±0.013	±0.025	±0.025
H	±0.013	±0.013	±0.025
E	±0.025	±0.025	±0.025
G	±0.025	±0.025	±0.13
J	±0.005	±0.05~±0.13	±0.025
K*	±0.013	±0.05~±0.13	±0.025
L*	±0.025	±0.05~±0.13	±0.025
M*	±0.08~±0.20	±0.05~±0.13	±0.13
N*	±0.08~±0.20	±0.05~±0.13	±0.025
U*	±0.13~±0.38	±0.08~±0.25	±0.13

As a rule, the sides of these inserts are as sintered. Tolerance differs with insert size, for the accuracy of class M, refer to the table on the right.

Triangular inserts with a facet (secondary cutting edge)

Detailed dimension of M class insert Insert height Tolerances (mm)					
Inscribed circle	T	S	C	D	V
6.35	±0.08	-	-	-	-
9.525	±0.08	±0.08	±0.11	±0.10	±0.13
12.70	±0.13	±0.13	±0.13	±0.15	-
15.875	±0.15	±0.15	±0.15	±0.18	-
19.05	±0.15	±0.15	±0.15	±0.18	-
25.40	-	±0.18	-	-	-
31.75	-	±0.25	-	-	-

Inscribed circle Tolerances (mm)					
Inscribed circle	T	S	C	D	V
6.35	±0.05	-	-	-	-
9.525	±0.05	±0.05	±0.05	±0.05	±0.05
12.70	±0.08	±0.08	±0.08	±0.08	±0.08
15.875	±0.10	±0.10	±0.10	±0.10	±0.10
19.05	-	-	-	-	±0.10
25.40	-	±0.13	-	-	±0.10
31.75	-	±0.20	-	-	±0.12

3 - Tolerances symbol

A	B	C	D	E
F	G	N	P	O
				Other clearance angle

2 - Normal clearance symbol

ISO	D	C	G	W
ANSI	D	C	G	W

4 - Insert symbol									
symbol	Type	Hole type	Chipbreaker	Shape	symbol	Type	Hole type	Chipbreaker	Shape
W	with hole	Round hole one countersink (40°-60°)	Without chipbreaker		G	with hole	Round hole	Chipbreaker on both sides	
T			Chipbreaker on one side		N	without hole	-	Without chipbreaker	
A	with hole	Round hole	Without chipbreaker		R	without hole	-	Chipbreaker on one side	
M			Chipbreaker on one side		X		-	-	-

R's	35° V's	55° D's	80° C's	90° S's	60° T's	80° W's	IC		ANSI
							mm	inch	Symbol
-	06	04	-	03	06	02	3,97	5/32	1,20
-	08	05	04	04	08	L3	4,76	3/16	1,50
-	09	06	05	05	09	03	5,56	7/32	1,80
06**	-	-	-	-	-	-	6,00	0,236	
06*	11	07	06	06	11	04	6,35	1/4	2,00
07*	13	09	08	07	13	05	7,94	5/16	2,50
08*	-	-	-	-	-	-	8,00	0,315	
09*	16	11	09	09	16	06	9,525	3/8	3,00
10**	-	-	-	-	-	-	10,00	0,394	
12**	-	-	-	-	-	-	12,00	0,472	
12*	22	15	12	12	22	08	12,70	1/2	4,00
15*	27	19	16	15	27	10	15,875	5/8	5,00
16**	-	-	-	-	-	-	16,00	0,63	
19*	33	23	19	19	33	13	19,05	3/4	6,00
20**	-	-	-	-	-	-	20,00	0,787	
25**	-	-	-	-	-	-	25,00	0,984	
25*	44	31	25	25	44	17	25,40	1,00	8,00
31*	54	38	32	31	54	21	31,75	1 1/4	10,00
32**	-	-	-	-	-	-	32,00	1,26	

\* ANSI designation only  
(Radius Designation is R0)

\*\* Metric designation only  
(Radius Designation is M0)

According to International Standard ISO 1832 - 2012(E)

"Indexable inserts for cutting tools - Designation"

ISO	mm	ANSI	inch
01	1.59	1	0.062
T1	1.98	1.2	0.078
02	2.38	1.5	0.094
03	3.18	2	0.125
T3	3.97	2.5	0.156
04	4.76	3	0.188
05	5.56	3.5	0.219
06	6.35	4	0.250
07	7.94	5	0.312
09	9.52	6	0.375
12	12.70	8	0.500

5 - Insert size symbol

6 - Insert thickness symbol

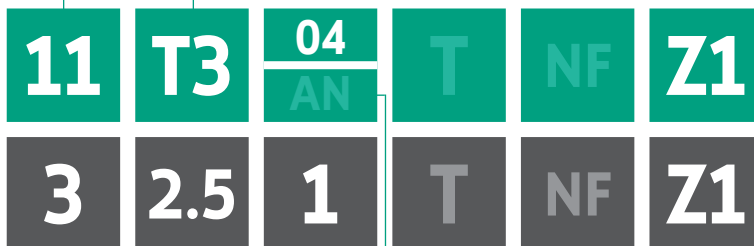

ISO	mm	inch	ANSI
00	Sharp nose		0
01	0.10	.004	0.2
02	0.20	.008	0.5
04	0.40	.015	1
08	0.80	.032	2
12	1.2	.047	3
16	1.6	.062	4
20	2.0	.078	5
24	2.4	.094	6
28	2.8	.109	7
32	3.2	.125	8
<sup>00</sup> (inch or M0/ metric)	Round insert		0

For inserts having secondary edges two digits are used:			
1 <sup>st</sup> digit is secondary edge		2 <sup>nd</sup> digit is secondary edges relief angle	
A	45°	A	3°
D	60°	B	5°
E	75°	C	7°
F	85°	D	15°
P	90°	E	20°
Z	special	F	25°
		G	30°
		N	0°
		P	11°
		Z	special

\*only when required.

Shape	Honing	Symbol
	No honing	F
	With honing	E
	Chamfered No honing	T
	Chamfered with honing	S

\*only when required.

Z1 (1 tip)	Z6 (6 tips)
Z2 (2 tips)	Z8 (8 tips)
Z3 (3 tips)	FL (Full edge left)
Z4 (4 tips)	FR (Full edge right)
Z5 (5 tips)	O (other)

NF	Finishing
----	-----------

# NEGATIVE INSERTS

## CN - RHOMBIC 80° NEGATIVE

RÔMBICA 80° NEGATIVA | RÓMBICA 80° NEGATIVA

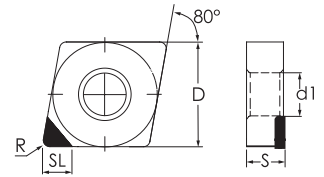

### CNGA Z1

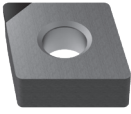
	(1) Geometry code	(2) Grade code		N		Dimensions Dimensões Dimensiones (mm)						Cutting conditions Condições de corte Condiciones de corte					
		ISO Reference	ANSI Reference	PDP410	PDP403	D	S	R	d1	W	SL	ap (mm)	Min	Max	fn (mm/r)	Min	Max
	1124228	CNGA 120404 Z1	CNGA 431 Z1	<input checked="" type="radio"/>	<input checked="" type="radio"/>	12,70	4,76	0,40	5,16	-	3,50	0,10	0,07	0,40	0,10	0,06	0,20
	1124110	CNGA 120408 Z1	CNGA 432 Z1	<input checked="" type="radio"/>	<input type="radio"/>	12,70	4,76	0,80	5,16	-	3,50	0,15	0,07	0,80	0,15	0,08	0,30
	1124229	CNGA 120412 Z1	CNGA 433 Z1	<input type="radio"/>	<input type="radio"/>	12,70	4,76	1,20	5,16	-	3,50	0,25	0,08	1,20	0,30	0,10	0,40
	1124230	CNGA 120416 Z1	CNGA 434 Z1	<input type="radio"/>	<input type="radio"/>	12,70	4,76	1,60	5,16	-	3,50	0,50	0,08	1,60	0,35	0,10	0,50

Stock Itens | Itens de stock

Available under request | Disponível sob consulta | Disponible bajo consulta

Insert Order Code: (1) Geometry code + (2) Grade code

## DN - RHOMBIC 55° NEGATIVE

RÔMBICA 55° NEGATIVA | RÓMBICA 55° NEGATIVA

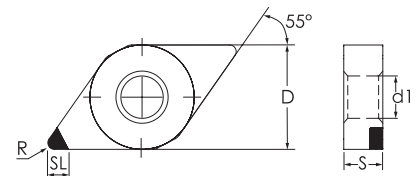

### DNGA Z1

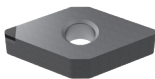
	(1) Geometry code	(2) Grade code		N		Dimensions Dimensões Dimensiones (mm)						Cutting conditions Condições de corte Condiciones de corte					
		ISO Reference	ANSI Reference	PDP410	PDP403	D	S	R	d1	W	SL	ap (mm)	Min	Max	fn (mm/r)	Min	Max
	1124235	DNGA 150404 Z1	DNGA 431 Z1	<input type="radio"/>	<input type="radio"/>	12,70	4,76	0,40	5,16	-	3,50	0,10	0,07	0,40	0,10	0,05	0,20
	1124236	DNGA 150408 Z1	DNGA 432 Z1	<input type="radio"/>	<input type="radio"/>	12,70	4,76	0,80	5,16	-	3,50	0,15	0,07	0,80	0,15	0,05	0,25
	1124362	DNGA 150608 Z1	DNGA 442 Z1	<input type="radio"/>	<input type="radio"/>	12,70	6,35	0,80	5,16	-	3,50	0,15	0,07	0,80	0,15	0,05	0,25
	1124363	DNGA 150612 Z1	DNGA 443 Z1	<input type="radio"/>	<input type="radio"/>	12,70	6,35	1,20	5,16	-	3,50	0,20	0,08	1,20	0,20	0,05	0,30

Stock Itens | Itens de stock

Available under request | Disponível sob consulta | Disponible bajo consulta

Insert Order Code: (1) Geometry code + (2) Grade code

## SN - SQUARE 90° NEGATIVE

QUADRADA 90° NEGATIVA | ESQUADRA 90° NEGATIVA

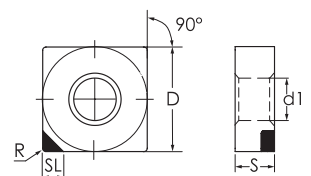

### SNGA Z1

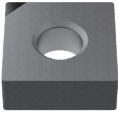
	(1) Geometry code	(2) Grade code		N		Dimensions Dimensões Dimensiones (mm)						Cutting conditions Condições de corte Condiciones de corte					
		ISO Reference	ANSI Reference	PDP410	PDP403	D	S	R	d1	W	SL	ap (mm)	Min	Max	fn (mm/r)	Min	Max
	1124243	SNGA 090304 Z1	SNGA 321 Z1	<input type="radio"/>	<input type="radio"/>	9,53	3,18	0,40	3,81	-	3,50	0,10	0,07	0,40	0,10	0,07	0,20
	1124244	SNGA 090308 Z1	SNGA 322 Z1	<input type="radio"/>	<input type="radio"/>	9,53	3,18	0,80	3,81	-	3,50	0,20	0,08	0,80	0,12	0,08	0,25
	1124245	SNGA 120404 Z1	SNGA 431 Z1	<input type="radio"/>	<input type="radio"/>	12,70	4,76	0,40	5,16	-	3,50	0,10	0,07	0,40	0,12	0,07	0,25
	1124246	SNGA 120408 Z1	SNGA 432 Z1	<input type="radio"/>	<input type="radio"/>	12,70	4,76	0,80	5,16	-	3,50	0,20	0,08	0,80	0,15	0,08	0,30

Stock Itens | Itens de stock

Available under request | Disponível sob consulta | Disponible bajo consulta

Insert Order Code: (1) Geometry code + (2) Grade code

PCD

Code key

Overview

Negative inserts

Positive inserts

Toric Mills

Tailor-made

TN - TRIANGULAR 60° NEGATIVE

TRIANGULAR 60° NEGATIVA | TRIANGULAR 60° NEGATIVA

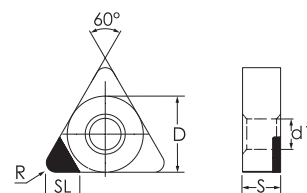

TNGA Z1

	<sup>(1)</sup> Geometry code	<sup>(2)</sup> Grade code		N		Dimensions Dimensões Dimensiones (mm)						Cutting conditions Condições de corte Condiciones de corte					
		ISO Reference	ANSI Reference	D6	I3	D	S	R	d1	W	SL	ap (mm)	Min	Max	fn (mm/r)	Min	Max
				PDP410	PDP403												
	1124256	TNGA 110304 Z1	TNGA 221 Z1	○	○	6,350	3,18	0,40	2,26	-	3,50	0,10	0,08	0,40	0,08	0,03	0,15
	1124257	TNGA 110308 Z1	TNGA 222 Z1	○	○	6,350	3,18	0,80	2,26	-	3,50	0,15	0,10	0,80	0,10	0,05	0,25
	1124258	TNGA 160404 Z1	TNGA 331 Z1	⊗	○	9,525	4,76	0,40	3,81	-	3,50	0,10	0,08	0,40	0,10	0,05	0,20
	1124259	TNGA 160408 Z1	TNGA 332 Z1	○	○	9,525	4,76	0,80	3,81	-	3,50	0,20	0,10	0,80	0,15	0,08	0,30
	1124385	TNGA 160412 Z1	TNGA 333 Z1	○	○	9,525	4,76	1,20	3,81	-	3,50	0,20	0,10	0,80	0,15	0,08	0,30

⊗ Stock Items | Itens de stock

○ Available under request | Disponível sob consulta | Disponible bajo consulta

Insert Order Code: <sup>(1)</sup>Geometry code + <sup>(2)</sup>Grade code

VN - RHOMBIC 35° NEGATIVE

RÔMBICA 35° NEGATIVA | RÔMBICA 35° NEGATIVA

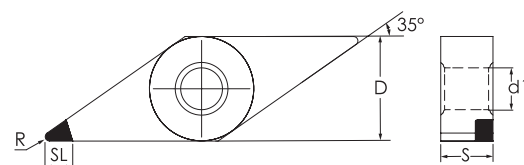

VNGA Z1

	<sup>(1)</sup> Geometry code	<sup>(2)</sup> Grade code		N		Dimensions Dimensões Dimensiones (mm)						Cutting conditions Condições de corte Condiciones de corte					
		ISO Reference	ANSI Reference	D6	I3	D	S	R	d1	W	SL	ap (mm)	Min	Max	fn (mm/r)	Min	Max
				PDP410	PDP403												
	1124285	VNGA 160404 Z1	VNGA 331 Z1	○	○	9,53	4,76	0,40	3,81	0,00	3,50	0,10	0,07	0,40	0,10	0,07	0,20
	1124286	VNGA 160408 Z1	VNGA 332 Z1	○	○	9,53	4,76	0,80	3,81	0,00	3,50	0,20	0,08	0,80	0,15	0,08	0,30
	1124287	VNGA 160412 Z1	VNGA 333 Z1	○	○	9,53	4,76	1,20	3,81	0,00	3,50	0,25	0,10	1,20	0,17	0,10	0,35

⊗ Stock Items | Itens de stock

○ Available under request | Disponível sob consulta | Disponible bajo consulta

Insert Order Code: <sup>(1)</sup>Geometry code + <sup>(2)</sup>Grade code

# POSITIVE INSERTS

OVERVIEW | VISTA GENÉRICA | VISIÓN GENERAL

## SINGLE TIP

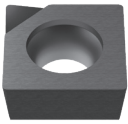
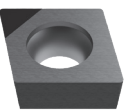
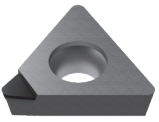
<b>SCGT Z1</b>		<b>SCGW Z1</b>					
							
Size 06   09   12		Size 06   09   12					
Page 11							
<b>CCGT Z1</b>		<b>CCGW Z1</b>		<b>CPGT Z1</b>		<b>CPGW Z1</b>	
							
Size 06   09   12		Size 06   09   12		Size 06   09   12		Size 06   09   12	
Page 12				Page 13			
<b>DCGT Z1</b>		<b>DCGW Z1</b>					
							
Size 07   11		Size 07   11   15					
Page 14							
<b>VCGT Z1</b>		<b>VCGW Z1</b>					
							
Size 07   11   16		Size 07   11   16					
Page 15							
<b>TCGT Z1</b>		<b>TCGW Z1</b>		<b>TPGT Z1</b>		<b>TPGW Z1</b>	
							
Size 09   11   16		Size 09   11   16		Size 11   16		Size 11   16	
Page 16				Page 17			

## FULL EDGE

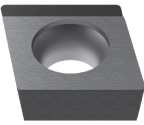
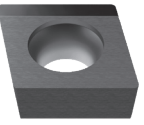
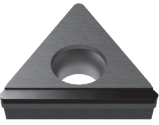
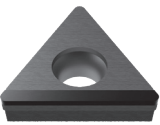
<b>CCGT FR/FL</b>		<b>CCGW FR/FL</b>		<b>TCGT FL</b>		<b>TCGW FL</b>	
							
Size 06   09   12		Size 06   09   12		Size 11   16		Size 11   16   22	
Page 18				Page 19			

PCD

Code key

Overview

Negative inserts

Positive inserts

Toric Mills

Tailor-made

SC = SQUARE 90° POSITIVE  
 QUADRADA 90° POSITIVA | ESQUADRA 90° POSITIVA

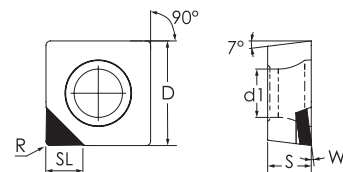

SCGT Z1

	(1) Geometry code	(2) Grade code		N		Dimensions Dimensões Dimensiones (mm)							Cutting conditions Condições de corte Condiciones de corte				
				D6	I3	D	S	R	d1	W	SL	ap (mm)	Min	Max	fn (mm/r)	Min	Max
				PDP410	PDP403												
	1124386	SCGT 060202 Z1	SCGT 21.50.5 Z1	○	○	6,35	2,38	0,20	2,80	7°	3,50	0,08	0,05	0,20	0,07	0,05	0,15
	1124387	SCGT 060204 Z1	SCGT 21.51 Z1	○	○	6,35	2,38	0,40	2,80	7°	3,50	0,10	0,05	0,40	0,09	0,05	0,20
	1124388	SCGT 09T304 Z1	SCGT 32.51 Z1	○	○	9,52	3,97	0,40	4,40	10°	3,50	0,10	0,07	0,40	0,10	0,05	0,20
	1124389	SCGT 09T308 Z1	SCGT 32.52 Z1	⊗	○	9,52	3,97	0,80	4,40	10°	3,50	0,20	0,08	0,80	0,15	0,07	0,30
	1124390	SCGT 120404 Z1	SCGT 431 Z1	○	○	12,70	4,76	0,40	5,50	10°	3,50	0,12	0,07	0,40	0,10	0,05	0,20
	1124391	SCGT 120408 Z1	SCGT 432 Z1	⊗	○	12,70	4,76	0,80	5,50	10°	3,50	0,22	0,08	0,80	0,15	0,08	0,30

⊗ Stock Items | Itens de stock

○ Available under request | Disponível sob consulta | Disponible bajo consulta

Insert Order Code: (1) Geometry code + (2) Grade code

SCGW Z1

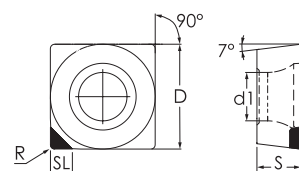

	(1) Geometry code	(2) Grade code		N		Dimensions Dimensões Dimensiones (mm)							Cutting conditions Condições de corte Condiciones de corte				
				D6	I3	D	S	R	L	W	SL	ap (mm)	Min	Max	fn (mm/r)	Min	Max
				PDP410	PDP403												
	1124237	SCGW 060202 Z1	SCGW 21.50.5 Z1	○	○	6,35	2,38	0,20	6,35	-	3,50	0,08	0,05	0,20	0,07	0,05	0,15
	1124238	SCGW 060204 Z1	SCGW 21.51 Z1	○	○	6,35	2,38	0,40	6,35	-	3,50	0,10	0,05	0,40	0,09	0,05	0,20
	1124239	SCGW 09T304 Z1	SCGW 32.51 Z1	○	○	9,53	3,97	0,40	9,53	-	3,50	0,10	0,07	0,40	0,10	0,05	0,20
	1124240	SCGW 09T308 Z1	SCGW 32.52 Z1	○	○	9,53	3,97	0,80	9,53	-	3,50	0,20	0,08	0,80	0,15	0,07	0,30
	1124794	SCGW 09T312 Z1	SCGW 32.53 Z1	○	○	6,35	3,96	1,20	6,35	-	3,50	0,30	0,09	1,20	0,20	0,10	0,40
	1124241	SCGW 120404 Z1	SCGW 431 Z1	○	○	12,70	4,76	0,40	12,70	-	3,50	0,12	0,07	0,40	0,10	0,05	0,20
	1124242	SCGW 120408 Z1	SCGW 432 Z1	○	○	12,70	4,76	0,80	12,70	-	3,50	0,22	0,08	0,80	0,15	0,08	0,30

⊗ Stock Items | Itens de stock

○ Available under request | Disponível sob consulta | Disponible bajo consulta

Insert Order Code: (1) Geometry code + (2) Grade code

PCD

Code key

Overview

Negative inserts

Positive inserts

Toric Mills

Tailor-made

# POSITIVE INSERTS

## CC - RHOMBIC 80° POSITIVE

RÔMBICA 80° POSITIVA | RÓMBICA 80° POSITIVA

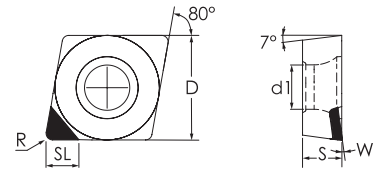

### CCGT Z1

	(1) Geometry code	(2) Grade code		N		Dimensions Dimensões Dimensiones (mm)						Cutting conditions Condições de corte Condiciones de corte					
		ISO Reference	ANSI Reference	D6	I3	D	S	R	d1	W	SL	ap (mm)	Min	Max	fn (mm/r)	Min	Max
				PDP410	PDP403												
	1124113	CCGT 060202 Z1	CCGT 21.50.5 Z1	⊗	○	6,35	2,38	0,20	2,80	7°	3,50	0,08	0,05	0,20	0,08	0,05	0,15
	1124209	CCGT 060204 Z1	CCGT 21.51 Z1	○	○	6,35	2,38	0,40	2,80	7°	3,50	0,10	0,07	0,40	0,12	0,07	0,25
	1124487	CCGT 060220 Z1	CCGT 21.55 Z1	○	○	6,35	2,38	2,00	2,80	10°	3,14	0,20	0,10	0,50	0,15	0,10	0,30
	1112592	CCGT 09T304 Z1	CCGT 32.51 Z1	⊗	○	9,53	3,97	0,40	4,40	10°	3,50	0,10	0,07	0,40	0,12	0,07	0,25
	1124210	CCGT 09T308 Z1	CCGT 32.52 Z1	○	○	9,53	3,97	0,80	4,40	10°	3,50	0,20	0,08	0,80	0,15	0,08	0,30
	1124211	CCGT 120404 Z1	CCGT 431 Z1	⊗	○	12,70	4,76	0,40	5,50	10°	3,50	0,10	0,07	0,40	0,12	0,07	0,25
	1112630	CCGT 120408 Z1	CCGT 432 Z1	⊗	○	12,70	4,76	0,80	5,50	10°	3,50	0,20	0,08	0,80	0,15	0,08	0,30
	1124465	CCGT 09T304-NF Z1	CCGT 32.51-NF Z1	⊗	○	9,53	3,97	0,40	4,40	-	4,00	0,12	0,07	0,40	0,15	0,07	0,25
	1124726	CCGT 09T308-NF Z1	CCGT 32.52-NF Z1	⊗	○	9,53	3,97	0,80	4,40	-	4,00	0,20	0,08	0,80	0,20	0,08	0,30

⊗ Stock Items | Itens de stock

○ Available under request | Disponível sob consulta | Disponible bajo consulta

Insert Order Code: (1) Geometry code + (2) Grade code

PCD

Code key

Overview

Negative inserts

Positive inserts

Toric Mills

Tailor-made

### CCGW Z1

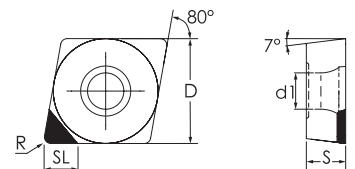

	(1) Geometry code	(2) Grade code		N		Dimensions Dimensões Dimensiones (mm)						Cutting conditions Condições de corte Condiciones de corte					
		ISO Reference	ANSI Reference	D6	I3	D	S	R	d1	W	SL	ap (mm)	Min	Max	fn (mm/r)	Min	Max
				PDP410	PDP403												
	1124114	CCGW 060202 Z1	CCGW 21.50.5 Z1	⊗	○	6,35	2,38	0,20	2,80	-	3,50	0,08	0,05	0,20	0,08	0,05	0,13
	1124218	CCGW 060204 Z1	CCGW 21.51 Z1	⊗	○	6,35	2,38	0,40	2,80	-	3,50	0,10	0,07	0,40	0,11	0,07	0,23
	1124793	CCGW 060220 Z1	CCGW 21.55 Z1	⊗	○	6,35	2,38	2,00	2,80	-	3,20	0,80	0,40	2,00	0,15	0,10	0,40
	1124219	CCGW 09T302 Z1	CCGW 32.50.5 Z1	○	○	9,53	3,97	0,20	4,40	-	3,50	0,08	0,05	0,20	0,08	0,05	0,15
	1112593	CCGW 09T304 Z1	CCGW 32.51 Z1	⊗	○	9,53	3,97	0,40	4,40	-	3,50	0,10	0,07	0,40	0,12	0,06	0,25
	1124220	CCGW 09T308 Z1	CCGW 32.2 Z1	○	○	9,53	3,97	0,80	4,40	-	3,50	0,20	0,08	0,80	0,15	0,08	0,30
	1124221	CCGW 120404 Z1	CCGW 431 Z1	⊗	○	12,70	4,76	0,40	5,50	-	3,50	0,10	0,07	0,40	0,12	0,06	0,25
	1112631	CCGW 120408 Z1	CCGW 432 Z1	⊗	○	12,70	4,76	0,80	5,50	-	3,50	0,20	0,08	0,80	0,15	0,08	0,30

⊗ Stock Items | Itens de stock

○ Available under request | Disponível sob consulta | Disponible bajo consulta

Insert Order Code: (1) Geometry code + (2) Grade code

CP = RHOMBIC 80° POSITIVE

RÔMBICA 80° POSITIVA | RÓMBICA 80° POSITIVA

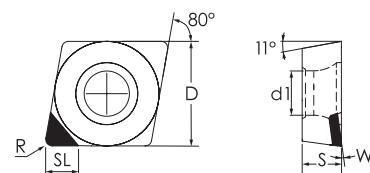

CPGT Z1

	<sup>(1)</sup> Geometry code	<sup>(2)</sup> Grade code		N		Dimensions Dimensões Dimensiones (mm)						Cutting conditions Condições de corte Condiciones de corte					
				D6	I3	D	S	R	d1	W	SL	ap (mm)	Min	Max	fn (mm/r)	Min	Max
				PDP410	PDP403												
	1124392	CPGT 060202 Z1	CCGT 21.50.5 Z1	○	○	6,35	2,38	0,20	2,80	7°	3,50	0,08	0,05	0,2	0,08	0,05	0,15
	1124393	CPGT 060204 Z1	CCGT 21.51 Z1	○	○	6,35	2,38	0,40	2,80	7°	3,50	0,10	0,07	0,4	0,12	0,07	0,25
	1124394	CPGT 09T304 Z1	CCGT 32.51 Z1	○	○	9,53	3,97	0,40	4,40	10°	3,50	0,10	0,07	0,4	0,12	0,07	0,25
	1124395	CPGT 09T308 Z1	CCGT 32.52 Z1	○	○	9,53	3,97	0,80	4,40	10°	3,50	0,20	0,08	0,8	0,15	0,08	0,30
	1124396	CPGT 120404 Z1	CCGT 431 Z1	○	○	12,70	4,76	0,40	5,50	10°	3,50	0,10	0,07	0,4	0,12	0,07	0,25
	1124397	CPGT 120408 Z1	CCGT 432 Z1	○	○	12,70	4,76	0,80	5,50	10°	3,50	0,20	0,08	0,8	0,15	0,08	0,30

⊗ Stock items | Itens de stock

○ Available under request | Disponível sob consulta | Disponible bajo consulta

Insert Order Code: <sup>(1)</sup>Geometry code + <sup>(2)</sup>Grade code

CPGW Z1

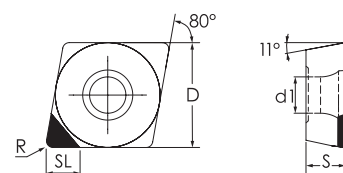

	<sup>(1)</sup> Geometry code	<sup>(2)</sup> Grade code		N		Dimensions Dimensões Dimensiones (mm)						Cutting conditions Condições de corte Condiciones de corte					
				D6	I3	D	S	R	d1	W	SL	ap (mm)	Min	Max	fn (mm/r)	Min	Max
				PDP410	PDP403												
	1124398	CPGW 060202 Z1	CPGW 21.50.5 Z1	○	○	6,35	2,38	0,20	2,80	-	3,50	0,08	0,05	0,20	0,08	0,05	0,13
	1124399	CPGW 060204 Z1	CPGW 21.51 Z1	○	○	6,35	2,38	0,40	2,80	-	3,50	0,10	0,07	0,40	0,11	0,07	0,23
	1124400	CPGW 09T302 Z1	CPGW 32.50.5 Z1	○	○	9,53	3,97	0,20	4,40	-	3,50	0,08	0,05	0,20	0,08	0,05	0,15
	1124401	CPGW 09T304 Z1	CPGW 32.51 Z1	○	○	9,53	3,97	0,40	4,40	-	3,50	0,10	0,07	0,40	0,12	0,06	0,25
	1124402	CPGW 09T308 Z1	CPGW 32.52 Z1	○	○	9,53	3,97	0,80	4,40	-	3,50	0,20	0,08	0,80	0,15	0,08	0,30
	1124403	CPGW 120404 Z1	CPGW 431 Z1	○	○	12,70	4,76	0,40	5,50	-	3,50	0,10	0,07	0,40	0,12	0,06	0,25
	1124404	CPGW 120408 Z1	CPGW 432 Z1	○	○	12,70	4,76	0,80	5,50	-	3,50	0,20	0,08	0,80	0,15	0,08	0,30

⊗ Stock items | Itens de stock

○ Available under request | Disponível sob consulta | Disponible bajo consulta

Insert Order Code: <sup>(1)</sup>Geometry code + <sup>(2)</sup>Grade code

# POSITIVE INSERTS

## DC - RHOMBIC 55° POSITIVE

RÔMBICA 55° POSITIVA | RÓMBICA 55° POSITIVA

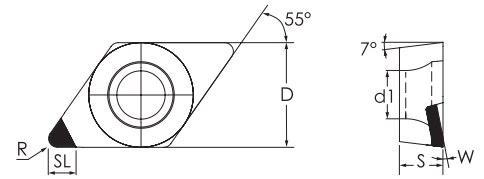

### DCGT Z1

	(1) Geometry code	(2) Grade code		N		Dimensions Dimensões Dimensiones (mm)						Cutting conditions Condições de corte Condiciones de corte					
		ISO Reference	ANSI Reference	D6	I3	D	S	R	d1	W	SL	ap (mm)	Min	Max	fn (mm/r)	Min	Max
				PDP410	PDP403												
	1124116	DCGT 070202 Z1	DCGT 21.50.5 Z1	⊗	○	6,35	2,38	0,20	2,80	7°	3,50	0,08	0,05	0,20	0,08	0,05	0,15
	1124231	DCGT 070204 Z1	DCGT 21.51 Z1	⊗	○	6,35	2,38	0,40	2,80	7°	3,50	0,10	0,07	0,40	0,10	0,05	0,20
	1112634	DCGT 11T304 Z1	DCGT 32.501 Z1	⊗	○	9,53	3,97	0,40	4,40	10°	3,50	0,10	0,07	0,40	0,10	0,05	0,20
	1124380	DCGT 11T308 Z1	DCGT 32.52 Z1	⊗	⊗	9,53	3,97	0,80	4,40	10°	3,50	0,20	0,08	0,80	0,15	0,08	0,30
	1124529	DCGT 150408 Z1	DCGT 432 Z1	⊗	○	12,70	4,76	0,80	5,50	10°	3,50	0,60	0,10	1,20	0,25	0,10	0,40

⊗ Stock Items | Itens de stock

○ Available under request | Disponível sob consulta | Disponible bajo consulta

Insert Order Code: (1) Geometry code + (2) Grade code

### DCGW Z1

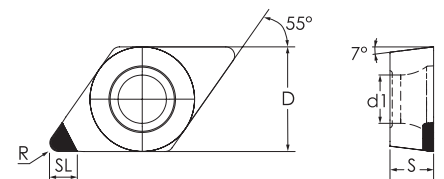

	(1) Geometry code	(2) Grade code		N		Dimensions Dimensões Dimensiones (mm)						Cutting conditions Condições de corte Condiciones de corte					
		ISO Reference	ANSI Reference	D6	I3	D	S	R	d1	W	SL	ap (mm)	Min	Max	fn (mm/r)	Min	Max
				PDP410	PDP403												
	1124232	DCGW 070202 Z1	DCGW 21.50.5 Z1	⊗	○	6,35	2,38	0,20	2,80	-	3,50	0,08	0,05	0,20	0,08	0,05	0,15
	1124233	DCGW 070204 Z1	DCGW 21.51 Z1	⊗	○	6,35	2,38	0,40	2,80	-	3,50	0,10	0,07	0,40	0,10	0,05	0,20
	1124458	DCGW 11T302 Z1	DCGW 32.50.5 Z1	⊗	○	9,53	3,97	0,20	4,40	-	3,50	0,10	0,05	0,35	0,10	0,05	0,15
	1112635	DCGW 11T304 Z1	DCGW 32.51 Z1	⊗	○	9,53	3,97	0,40	4,40	-	3,50	0,10	0,07	0,40	0,10	0,05	0,20
	1124168	DCGW 11T308 Z1	DCGW 32.52 Z1	⊗	○	9,53	3,97	0,80	4,40	-	3,50	0,20	0,08	0,80	0,15	0,08	0,30
	1124234	DCGW 150404 Z1	DCGW 431 Z1	○	○	12,70	4,76	0,40	5,50	-	3,50	0,10	0,08	0,40	0,10	0,05	0,20
	1124117	DCGW 150408 Z1	DCGW 432 Z1	⊗	○	12,70	4,76	0,80	5,50	-	3,50	0,20	0,10	0,80	0,15	0,08	0,30

⊗ Stock Items | Itens de stock

○ Available under request | Disponível sob consulta | Disponible bajo consulta

Insert Order Code: (1) Geometry code + (2) Grade code

PCD

Code key

Overview

Negative inserts

Positive inserts

Toric Mills

Tailor-made

VC = RHOMBIC 35° POSITIVE  
RÔMBICA 35° POSITIVA | RÓMBICA 35° POSITIVA

VCGT Z1

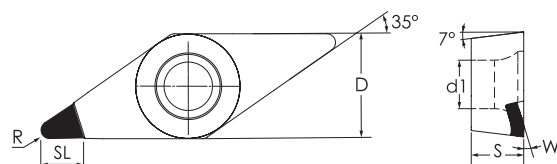

	(1) Geometry code	(2) Grade code		N		Dimensions Dimensões Dimensiones (mm)						Cutting conditions Condições de corte Condiciones de corte					
				D6	I3	D	S	R	d1	W	SL	ap (mm)	Min	Max	fn (mm/r)	Min	Max
				PDP410	PDP403												
	1124275	VCGT 070202 Z1	VCGT 1.31.50.5 Z1	○	○	3,97	2,38	0,20	2,20	7°	3,00	0,08	0,05	0,20	0,08	0,03	0,10
	1124276	VCGT 070204 Z1	VCGT 1.31.51 Z1	○	○	3,97	2,38	0,40	2,20	7°	3,00	0,10	0,07	0,40	0,10	0,05	0,20
	1124277	VCGT 110302 Z1	VCGT 220.5 Z1	⊗	○	6,35	3,18	0,20	2,80	10°	3,50	0,08	0,05	0,20	0,08	0,03	0,10
	1124071	VCGT 110304 Z1	VCGT 221 Z1	⊗	○	6,35	3,18	0,40	2,80	10°	3,50	0,10	0,07	0,40	0,10	0,05	0,20
	1124278	VCGT 160404 Z1	VCGT 331 Z1	⊗	○	9,53	4,76	0,40	4,40	10°	3,50	0,10	0,07	0,40	0,10	0,05	0,20
	1112640	VCGT 160408 Z1	VCGT 332 Z1	⊗	○	9,53	4,76	0,80	4,40	10°	3,50	0,20	0,08	0,80	0,15	0,08	0,30
	1124279	VCGT 160412 Z1	VCGT 333 Z1	○	○	9,53	4,76	1,20	4,40	10°	3,50	0,30	0,10	1,20	0,17	0,08	0,35

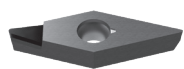

⊗ Stock Items | Itens de stock

○ Available under request | Disponível sob consulta | Disponible bajo consulta

Insert Order Code: (1) Geometry code + (2) Grade code

VCGW Z1

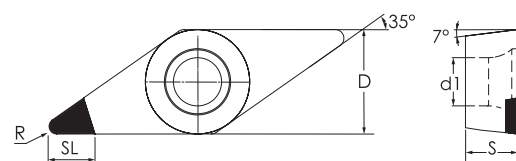

	(1) Geometry code	(2) Grade code		N		Dimensions Dimensões Dimensiones (mm)						Cutting conditions Condições de corte Condiciones de corte					
				D6	I3	D	S	R	d1	W	SL	ap (mm)	Min	Max	fn (mm/r)	Min	Max
				PDP410	PDP403												
	1124280	VCGW 070202 Z1	VCGW 1.31.50.5 Z1	○	○	3,97	2,38	0,20	2,20	-	3,00	0,08	0,05	0,20	0,08	0,03	0,10
	1124281	VCGW 070204 Z1	VCGW 1.31.51 Z1	⊗	○	3,97	2,38	0,40	2,20	-	3,00	0,10	0,07	0,40	0,10	0,05	0,20
	1124796	VCGW 110302 Z1	VCGW 220.5 Z1	⊗	○	6,35	3,18	0,20	2,80	-	3,50	0,13	0,05	0,20	0,10	0,05	0,15
	1124378	VCGW 110304 Z1	VCGW 221 Z1	⊗	○	6,35	3,18	0,40	2,80	-	3,50	0,10	0,07	0,40	0,10	0,05	0,20
	1124282	VCGW 110308 Z1	VCGW 222 Z1	⊗	○	6,35	3,18	0,80	2,80	-	3,50	0,20	0,08	0,80	0,15	0,08	0,30
	1124795	VCGW 160402 Z1	VCGW 330.5 Z1	⊗	○	9,53	4,76	0,20	4,40	-	3,50	0,18	0,05	0,30	0,10	0,05	0,15
	1124283	VCGW 160404 Z1	VCGW 331 Z1	⊗	○	9,53	4,76	0,40	4,40	-	3,50	0,10	0,07	0,40	0,10	0,05	0,20
	1112641	VCGW 160408 Z1	VCGW 332 Z1	⊗	○	9,53	4,76	0,80	4,40	-	4,00	0,20	0,08	0,80	0,15	0,08	0,30
	1124284	VCGW 160412 Z1	VCGW 333 Z1	⊗	○	9,53	4,76	1,20	4,40	-	3,50	0,30	0,10	1,20	0,17	0,08	0,35

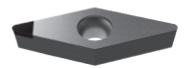

⊗ Stock Items | Itens de stock

○ Available under request | Disponível sob consulta | Disponible bajo consulta

Insert Order Code: (1) Geometry code + (2) Grade code

PCD

Code key

Overview

Negative inserts

Positive inserts

Toric Mills

Tailor-made

# POSITIVE INSERTS

## TC - TRIANGULAR 60° POSITIVE

TRIANGULAR 60° POSITIVA | TRIANGULAR 60° POSITIVA

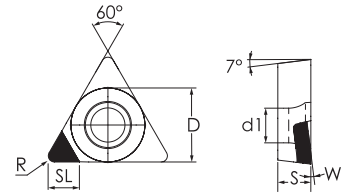

### TCGT Z1

	(1) Geometry code	(2) Grade code		N		Dimensions Dimensões Dimensiones (mm)						Cutting conditions Condições de corte Condiciones de corte					
				D6	I3	D	S	R	d1	W	SL	ap (mm)	Min	Max	fn (mm/r)	Min	Max
				PDP410	PDP403												
	1124186	TCGT 090202 Z1	TCGT 1.81.50.5 Z1			5,56	2,38	0,20	2,50	7°	3,00	0,07	0,04	0,20	0,07	0,03	0,10
	1124188	TCGT 090204 Z1	TCGT 1.81.51 Z1			5,56	2,38	0,40	2,50	7°	3,00	0,10	0,07	0,40	0,10	0,05	0,20
	1124501	TCGT 090208 Z1	TCGT 1.81.52 Z1			7,54	2,38	0,80	2,50	7°	3,00	0,45	0,10	0,80	0,18	0,08	0,30
	1124119	TCGT 110204 Z1	TCGT 21.51 Z1			6,35	2,38	0,40	2,80	7°	3,00	0,10	0,07	0,40	0,10	0,05	0,20
	1124190	TCGT 110208 Z1	TCGT 21.52 Z1			6,35	2,38	0,80	2,80	7°	3,00	0,20	0,08	0,80	0,15	0,08	0,30
	1124247	TCGT 16T304 Z1	TCGT 32.51 Z1			9,53	3,97	0,40	4,40	10°	3,00	0,10	0,07	0,40	0,10	0,05	0,20
	1112637	TCGT 16T308 Z1	TCGT 32.52 Z1			9,53	3,97	0,80	4,40	10°	3,00	0,20	0,08	0,80	0,15	0,08	0,30

Stock Items | Itens de stock

Available under request | Disponível sob consulta | Disponible bajo consulta

Insert Order Code: (1) Geometry code + (2) Grade code

PCD

### TCGW Z1

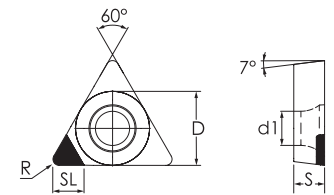

	(1) Geometry code	(2) Grade code		N		Dimensions Dimensões Dimensiones (mm)						Cutting conditions Condições de corte Condiciones de corte					
				D6	I3	D	S	R	d1	W	SL	ap (mm)	Min	Max	fn (mm/r)	Min	Max
				PDP410	PDP403												
	1124185	TCGW 090202 Z1	TCGW 1.81.50.5 Z1			5,56	2,38	0,20	2,50	-	3,00	0,07	0,04	0,20	0,07	0,03	0,10
	1124187	TCGW 090204 Z1	TCGW 1.81.51 Z1			5,56	2,38	0,40	2,50	-	3,00	0,10	0,07	0,40	0,10	0,05	0,20
	1124507	TCGW 110202 Z1	TCGW 21.50.5 Z1			6,35	2,38	0,20	2,80	-	3,00	0,07	0,04	0,20	0,07	0,03	0,10
	1124192	TCGW 110204 Z1	TCGW 21.51 Z1			6,35	2,38	0,40	2,80	-	3,50	0,10	0,07	0,40	0,10	0,05	0,20
	1124189	TCGW 110208 Z1	TCGW 21.52 Z1			6,35	2,38	0,80	2,80	-	3,50	0,20	0,08	0,80	0,15	0,08	0,30
	1124251	TCGW 16T304 Z1	TCGW 32.51 Z1			9,53	3,97	0,40	4,40	-	3,50	0,10	0,07	0,40	0,10	0,05	0,20
	1112638	TCGW 16T308 Z1	TCGW 32.52 Z1			9,53	3,97	0,80	4,40	-	3,50	0,20	0,08	0,80	0,15	0,08	0,30

Stock Items | Itens de stock

Available under request | Disponível sob consulta | Disponible bajo consulta

Insert Order Code: (1) Geometry code + (2) Grade code

Code key

Overview

Negative inserts

Positive inserts

Toric Mills

Tailor-made

TP - TRIANGULAR 60° POSITIVE

TRIANGULAR 60° POSITIVA | TRIANGULAR 60° POSITIVA

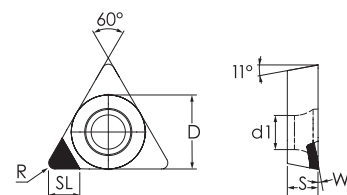

TPGT Z1

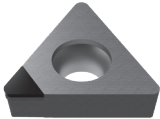
	(1) Geometry code	(2) Grade code		N		Dimensions Dimensões Dimensiones (mm)						Cutting conditions Condições de corte Condiciones de corte					
				D6	I3	D	S	R	d1	W	SL	ap (mm)	Min	Max	fn (mm/r)	Min	Max
				PDP410	PDP403												
	1124260	TPGT 110302 Z1	TPGT 220.5 Z1	○	○	6,35	3,18	0,20	3,40	10°	3,50	0,07	0,04	0,20	0,07	0,05	0,10
	1124261	TPGT 110304 Z1	TPGT 221 Z1	○	○	6,35	3,18	0,40	3,40	10°	3,50	0,10	0,07	0,40	0,10	0,05	0,20
	1124262	TPGT 110308 Z1	TPGT 222 Z1	○	○	6,35	3,18	0,80	3,40	10°	3,50	0,20	0,08	0,80	0,15	0,08	0,30
	1124263	TPGT 16T304 Z1	TPGT 32.51 Z1	○	○	9,53	3,97	0,40	4,30	10°	3,50	0,10	0,07	0,40	0,10	0,05	0,20
	1124174	TPGT 16T308 Z1	TPGT 32.52 Z1	○	○	9,53	3,97	0,80	4,30	10°	3,50	0,20	0,08	0,80	0,15	0,08	0,30
	1124264	TPGT 160404 Z1	TPGT 331 Z1	○	○	9,53	4,76	0,40	4,30	10°	3,50	0,10	0,07	0,40	0,10	0,05	0,20
	1124265	TPGT 160408 Z1	TPGT 332 Z1	○	○	9,53	4,76	0,80	4,30	10°	3,50	0,20	0,08	0,80	0,15	0,08	0,30

Stock Items | Itens de stock

Available under request | Disponível sob consulta | Disponible bajo consulta

Insert Order Code: (1) Geometry code + (2) Grade code

TPGW Z1

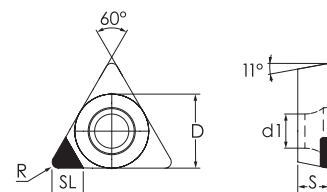

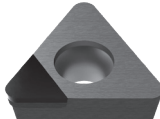
	(1) Geometry code	(2) Grade code		N		Dimensions Dimensões Dimensiones (mm)						Cutting conditions Condições de corte Condiciones de corte					
				D6	I3	D	S	R	d1	W	SL	ap (mm)	Min	Max	fn (mm/r)	Min	Max
				PDP410	PDP403												
	1124266	TPGW 110202 Z1	TPGW 21.50.5 Z1	○	○	6,35	2,38	0,20	2,80	-	3,50	0,07	0,04	0,20	0,07	0,05	0,10
	1124267	TPGW 110204 Z1	TPGW 21.51 Z1	○	○	6,35	2,38	0,40	2,80	-	3,50	0,10	0,07	0,40	0,10	0,05	0,20
	1124268	TPGW 110208 Z1	TPGW 21.52 Z1	○	○	6,35	2,38	0,80	2,80	-	3,50	0,20	0,08	0,80	0,15	0,08	0,30
	1124269	TPGW 110302 Z1	TPGW 220.5 Z1	○	○	6,35	3,18	0,20	2,80	-	3,50	0,07	0,04	0,20	0,07	0,05	0,10
	1124270	TPGW 110304 Z1	TPGW 221 Z1	⊗	○	6,35	3,18	0,40	2,80	-	3,50	0,10	0,07	0,40	0,10	0,05	0,20
	1124379	TPGW 110308 Z1	TPGW 222 Z1	⊗	○	6,35	3,18	0,80	2,80	-	3,50	0,20	0,08	0,80	0,15	0,08	0,30
	1124271	TPGW 16T304 Z1	TPGW 32.51 Z1	○	○	9,53	3,97	0,40	4,30	-	3,50	0,10	0,07	0,40	0,10	0,05	0,20
	1124272	TPGW 16T308 Z1	TPGW 32.52 Z1	○	○	9,53	3,97	0,80	4,30	-	3,50	0,20	0,08	0,80	0,15	0,08	0,30
	1124273	TPGW 160404 Z1	TPGW 331 Z1	○	○	9,53	4,76	0,40	4,30	-	3,50	0,10	0,07	0,40	0,10	0,05	0,20
	1124274	TPGW 160408 Z1	TPGW 332 Z1	○	○	9,53	4,76	0,80	4,30	-	3,50	0,20	0,08	0,80	0,15	0,08	0,30

Stock Items | Itens de stock

Available under request | Disponível sob consulta | Disponible bajo consulta

Insert Order Code: (1) Geometry code + (2) Grade code

PCD

Code key

Overview

Negative inserts

Positive inserts

Toric Mills

Tailor-made

# POSITIVE INSERTS

CC = RHOMBIC 80° POSITIVE  
RÔMBICA 80° POSITIVA | RÓMBICA 80° POSITIVA

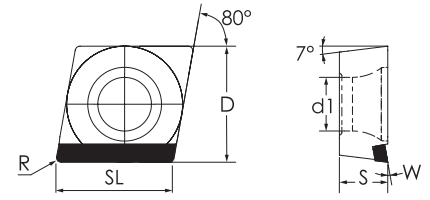

## CCGT FR/FL

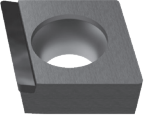
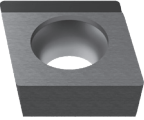
	(1) Geometry code	(2) Grade code		N		Dimensions Dimensões Dimensiones (mm)							Cutting conditions Condições de corte Condiciones de corte				
		ISO Reference	ANSI Reference	D6	I3	L	S	R	D	W	SL	ap (mm)	Min	Max	fn (mm/r)	Min	Max
				PDP410	PDP403												
 CCGT FR	1124212	CCGT 09T302 FR	CCGT 32.50.5 FR	○	○	9,53	3,97	0,20	4,40	10°	9,70	4,85	0,2	6,40	0,08	0,05	0,15
	1124165	CCGT 09T304 FR	CCGT 32.51 FR	⊗	○	9,53	3,97	0,40	4,40	10°	9,70	4,85	0,40	6,40	0,12	0,07	0,25
	1124213	CCGT 120404 FR	CCGT 431 FR	○	○	12,70	4,76	0,40	5,50	10°	12,90	6,45	0,40	8,50	0,15	0,08	0,30
	1124214	CCGT 120408 FR	CCGT 432 FR	○	○	12,70	4,76	0,80	5,50	10°	12,90	6,45	0,80	8,50	0,3	0,10	0,40
 CCGT FL	1124215	CCGT 09T302 FL	CCGT 32.50.5 FL	○	○	9,53	3,97	0,20	4,40	10°	9,70	4,85	0,20	6,40	0,08	0,05	0,15
	1124166	CCGT 09T304 FL	CCGT 32.51 FL	⊗	○	9,53	3,97	0,40	4,40	10°	9,70	4,85	0,40	6,40	0,12	0,07	0,25
	1124216	CCGT 120404 FL	CCGT 431 FL	⊗	○	12,70	4,76	0,40	5,50	10°	12,90	6,45	0,40	8,50	0,15	0,08	0,30
	1124217	CCGT 120408 FL	CCGT 432 FL	⊗	○	12,70	4,76	0,80	5,50	10°	12,90	6,45	0,80	8,50	0,30	0,10	0,40

⊗ Stock Itens | Itens de stock

○ Available under request | Disponível sob consulta | Disponible bajo consulta

Insert Order Code: (1) Geometry code + (2) Grade code

PCD

Code key

Overview

Negative inserts

Positive inserts

Toric Mills

Tailor-made

## CCGW FR/FL

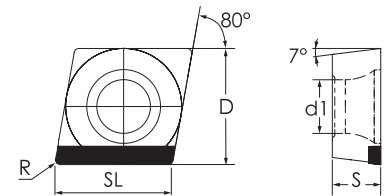

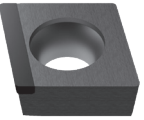
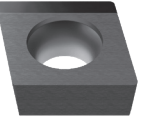
	(1) Geometry code	(2) Grade code		N		Dimensions Dimensões Dimensiones (mm)							Cutting conditions Condições de corte Condiciones de corte				
		ISO Reference	ANSI Reference	D6	I3	D	S	R	d1	W	SL	ap (mm)	Min	Max	fn (mm/r)	Min	Max
				PDP410	PDP403												
 CCGW FR	1124547	CCGW 060204 FR	CCGW 21.51 FR	⊗	○	9,53	3,97	0,40	4,40	-	9,70	4,85	0,40	6,40	0,12	0,07	0,25
	1124170	CCGW 09T304 FR	CCGW 32.51 FR	○	○	9,53	3,97	0,40	4,40	-	9,70	4,85	0,40	6,40	0,12	0,07	0,25
	1124222	CCGW 09T308 FR	CCGW 32.52 FR	○	○	9,53	3,97	0,80	4,40	-	9,70	4,85	0,80	6,40	0,16	0,10	0,35
	1124223	CCGW 120404 FR	CCGW 431 FR	○	○	12,70	4,76	0,40	5,50	-	12,90	6,45	0,40	8,50	0,15	0,08	0,30
 CCGW FL	1124224	CCGW 120408 FR	CCGW 432 FR	○	○	12,70	4,76	0,80	5,50	-	12,90	6,45	0,80	8,50	0,3	0,10	0,40
	1124548	CCGW 060204 FL	CCGW 21.51 FL	⊗	○	6,35	2,38	0,40	2,80	-	6,50	3,25	0,40	4,20	0,08	0,07	0,25
	1124171	CCGW 09T304 FL	CCGW 32.51 FL	○	○	9,53	3,97	0,40	4,40	-	9,70	4,85	0,40	6,40	0,12	0,07	0,25
	1124225	CCGW 09T308 FL	CCGW 32.52 FL	○	○	9,53	3,97	0,80	4,40	-	9,70	4,85	0,80	6,40	0,16	0,10	0,35
	1124226	CCGW 120404 FL	CCGW 431 FL	○	○	12,70	4,76	0,40	5,50	-	12,90	6,45	0,40	8,50	0,15	0,08	0,30
1124227	CCGW 120408 FL	CCGW 432 FL	⊗	○	12,70	4,76	0,80	5,50	-	12,90	6,45	0,80	8,50	0,30	0,10	0,40	

⊗ Stock Itens | Itens de stock

○ Available under request | Disponível sob consulta | Disponible bajo consulta

Insert Order Code: (1) Geometry code + (2) Grade code

TC - TRIANGULAR 60° POSITIVE  
 TRIÂNGULAR 60° POSITIVA | TRIANGULAR 60° POSITIVA

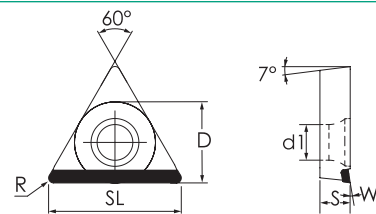

TCGT FL

	<sup>(1)</sup> Geometry code	<sup>(2)</sup> Grade code		N		Dimensions Dimensões Dimensiones (mm)						Cutting conditions Condições de corte Condiciones de corte					
				D6	I3	D	S	R	d1	W	SL	ap (mm)	Min	Max	fn (mm/r)	Min	Max
				PDP410	PDP403												
	1124173	TCGT 110204 FL	TCGT 21.51 FL			6,35	2,38	0,40	2,80	7°	10,41	5,20	0,40	6,90	0,10	0,05	0,20
	1124248	TCGT 110208 FL	TCGT 21.52 FL			6,35	2,38	0,80	2,80	7°	9,83	4,92	0,80	6,50	0,15	0,08	0,30
	1124249	TCGT 16T304 FL	TCGT 32.51 FL			9,53	3,97	0,40	4,40	10°	15,91	7,96	0,40	10,50	0,10	0,05	0,20
	1124250	TCGT 16T308 FL	TCGT 32.52 FL			9,53	3,97	0,80	4,40	10°	15,33	7,67	0,80	10,15	0,15	0,08	0,30

Stock Items | Itens de stock

Available under request | Disponível sob consulta | Disponible bajo consulta

Insert Order Code: <sup>(1)</sup>Geometry code + <sup>(2)</sup>Grade code

Note: Can be used as FR geometry.

TCGW FL

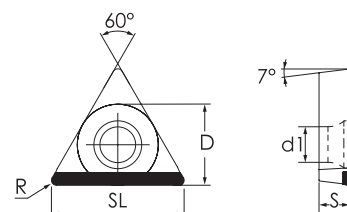

	<sup>(1)</sup> Geometry code	<sup>(2)</sup> Grade code		N		Dimensions Dimensões Dimensiones (mm)						Cutting conditions Condições de corte Condiciones de corte					
				D6	I3	D	S	R	d1	W	SL	ap (mm)	Min	Max	fn (mm/r)	Min	Max
				PDP410	PDP403												
	1124252	TCGW 110202 FL	TCGW 21.50.5 FL			6,35	2,38	0,20	2,80	-	10,71	5,20	0,40	6,90	0,10	0,05	0,20
	1112777	TCGW 110204 FL	TCGW 21.51 FL			6,35	2,38	0,40	2,80	-	10,41	5,21	0,80	6,50	0,15	0,08	0,30
	1124253	TCGW 16T304 FL	TCGW 32.51 FL			9,53	3,97	0,40	4,40	-	15,91	7,96	0,40	10,50	0,10	0,05	0,20
	1124254	TCGW 16T308 FL	TCGW 32.52 FL			9,53	3,97	0,80	4,40	-	15,33	7,67	0,80	10,15	0,15	0,08	0,30
	1124255	TCGW 220404 FL	TCGW 431 FL			12,70	4,76	0,40	5,50	-	21,40	8,00	0,40	10,70	0,10	0,08	0,20
	1124382	TCGW 220408 FL	TCGW 432 FL			12,70	4,76	0,80	5,50	-	20,83	7,84	0,80	10,45	0,15	0,10	0,30

Stock Items | Itens de stock

Available under request | Disponível sob consulta | Disponible bajo consulta

Insert Order Code: <sup>(1)</sup>Geometry code + <sup>(2)</sup>Grade code

Note: Can be used as FR geometry.

PCD

Code key

Overview

Negative inserts

Positive inserts

Toric Mills

Tailor-made



**HEADQUARTERS**

**PALBIT, S.A.**

P.O.Box 4 - Palhal

3854-908 - Branca ALB - Portugal

T (+351) 234540300 | F (+351) 234540301

palbit@palbit.pt

www.palbit.pt

**Branch office:**

**PALBIT México**

Emerson 150. Int.803-804. Colonia Chapultepec

Morales Delagación Miguel Hidalgo

C.P. 11570 México DF

T (+52) 5555 454 543 | F (+52) 5552 509 190

info@palbit.com.mx | www.palbit.com.mx

