

90090 | 90190 | 90390

TG PLUS

High performance on tangential shoulder milling

MILLING

Shouldering | Facing | Slotting



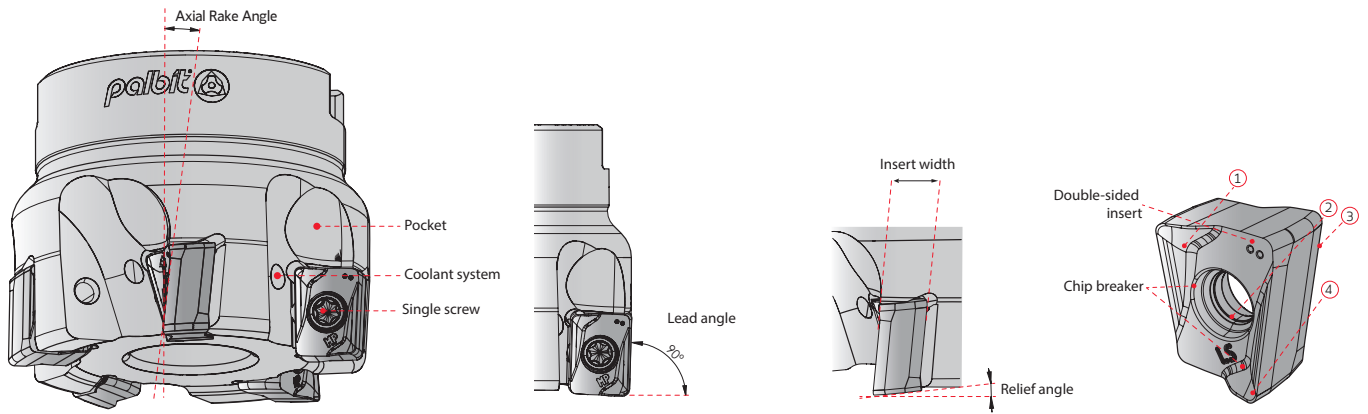

Positive Rake Angle

- For a smooth cutting;
- For low cutting forces;

Single screw

- Strong clamping system;

Pocket

- Better chip evacuation due to a wide pocket;

Coolant system

- Improvement of chip control and evacuation;
- Tool life improvement due to reduced cutting temperature;

True 90° wall

- 90° allows multi applications;
- Excellent for tangential shoulder milling;

Insert Width

- High thickness allows a stronger insert;

Relief angle

- Reduce the cutting load;
- Low cutting forces;

Double-sided insert

- 4 cutting edges;
- Negative insert has a strong edge;

COMPARATIVE CHAT Gráfico comparativo | Gráfico comparativo

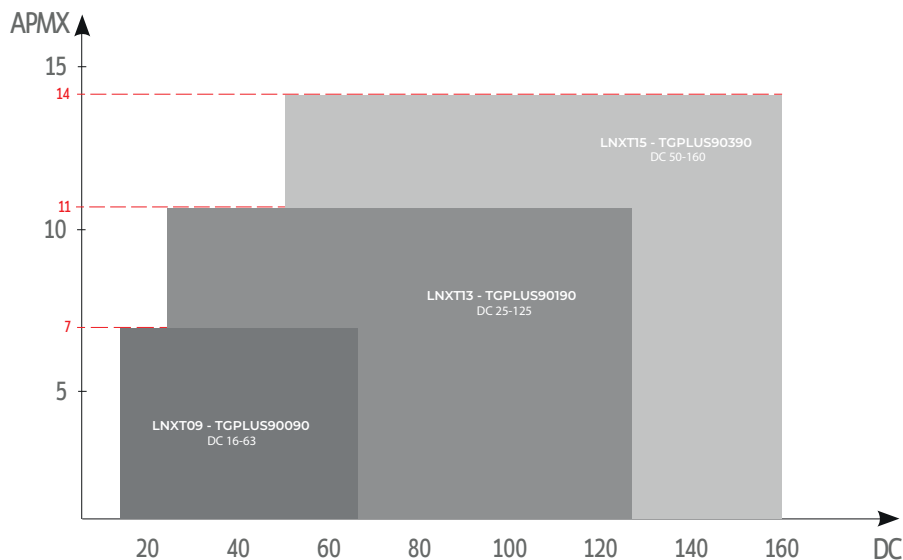

TGPLUS 90090
LNXT 09

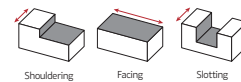

TGPLUS 90090

LNXT-MP

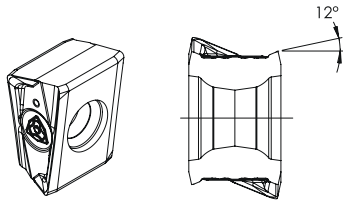

LNXT-LS

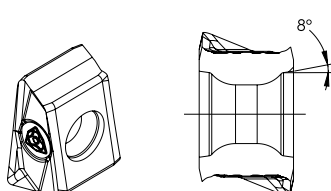

INSERT SIZE
09 LNXT
0904...

LNXT-MP

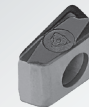

LNXT-MP



TGPLUS 90190

LNXT-MP

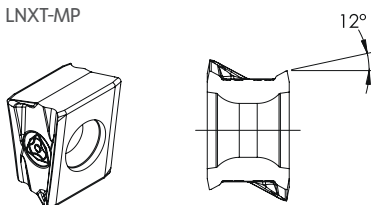

INSERT SIZE
13 LNXT
1306...

LNXT-MP

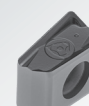

TGPLUS 90390

LNXT-MP

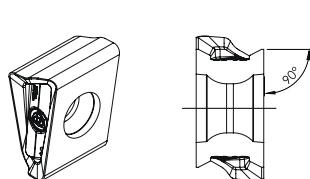

LNXT-HP

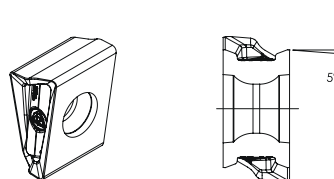

INSERT SIZE
15 LNXT
1506...

LNXT-MP

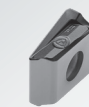

LNXT-HP

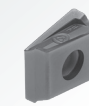

LNXT-W



LNXT-W

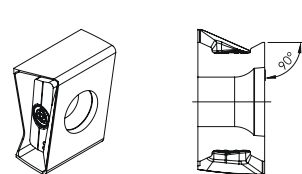

CHIP BREAKERS Quebra-aparas | Rompevirutas

Chip Breaker	Features Características Características
Geometry MP - General machining	Chip-breaker with a reinforced chamfer for general applications on steel and cast iron.
Geometry LS - Light machining	Positive top rake angle to promote a good chip flow and reduce power consumption on stainless steel and HRSA.
Geometry HP - Heavy machining of steels	Chip-breaker with a reinforced chamfer for Medium to heavy cutting conditions.
Geometry W - Wiper	Chip-breaker wiper for the best finishing solutions.



Arbor Mounting
KAPR=90° | GAMP=-4°

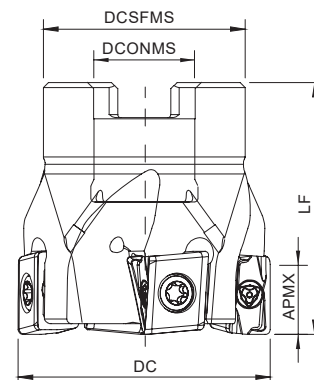

Order code Código	Reference Referência Referencia	CICT	Dimensions Dimensões Dimensiones (mm)				WT	Specifications		Insert Pastilha Inserto	Stock
			DC	DCONMS	DCSFMS	LF		Arbor Type	APMX (mm)		
181144400	040A90090-04-04-016040	4	40	16	36	40	0,24	A	7,0	LNXT 0904...	⊗
181144500	050A90090-05-04-022040	5	50	22	40	40	0,32	A	7,0	LNXT 0904...	⊗
181144600	063A90090-07-04-022040	7	63	22	48	40	0,54	A	7,0	LNXT 0904...	⊗
181146600	063A90090-10-04-022040	10	63	22	48	40	0,54	A	7,0	LNXT 0904...	⊗

⊗ Stock item | Produto de stock | Itens de stock

○ Available under request | Disponível sobre consulta | Disponible bajo consulta



Threaded Coupling
KAPR=90° | GAMP=-4°

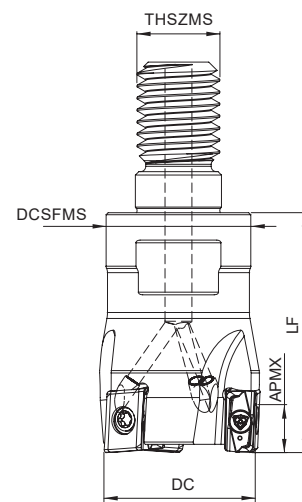

Order code Código	Reference Referência Referencia	CICT	Dimensions Dimensões Dimensiones (mm)				WT	Specifications	Insert Pastilha Inserto	Stock
			DC	THSZMS	DCSFMS	LF		APMX (mm)		
181144200	025R90090-03-04-M12035	3	25	12	21	35	0,10	7,0	LNXT 0904...	⊗
181144300	032R90090-04-04-M16040	4	32	16	29	40	0,21	7,0	LNXT 0904...	⊗

⊗ Stock item | Produto de stock | Itens de stock

○ Available under request | Disponível sobre consulta | Disponible bajo consulta

TGPLUS 90090
LNXT 09



Weldon Shank
KAPR=90° | GAMP=-4°(*-6°)

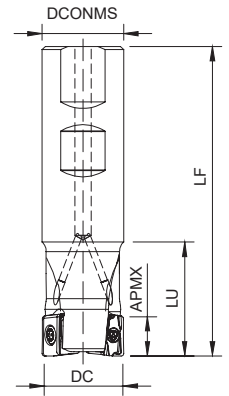

Order code Código	Reference Referência Referencia	CICT	Dimensions Dimensões Dimensiones (mm)				WT	Specifications	Insert Pastilha Inserto	Stock
			DC	DCONMS	LF	LU		APMX (mm)		
181109400	016W90090-02-06-016090*	2	16	16	90	25	0,12	7,0	LNXT 0904...	☉
181109500	025W90090-03-04-025095	3	25	25	95	30	0,31	7,0	LNXT 0904...	☉
181144100	032W90090-04-04-032110	4	32	32	110	30	0,61	7,0	LNXT 0904...	☉

☉ Stock item | Produto de stock | Itens de stock

○ Available under request | Disponível sobre consulta | Disponible bajo consulta



Cylindrical Shank
KAPR=90° | GAMP=-4°

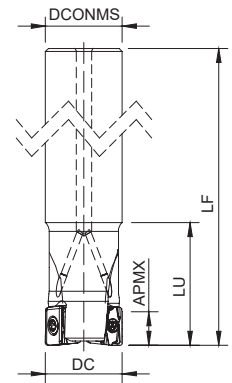

Order code Código	Reference Referência Referencia	CICT	Dimensions Dimensões Dimensiones (mm)				WT	Specifications	Insert Pastilha Inserto	Stock
			DC	DCONMS	LF	LU		APMX (mm)		
181158800	020E90090-02-04-020150	2	20	20	150	30	0,15	7,0	LNXT 0904...	☉
181148100	025E90090-03-04-025200	3	25	25	200	30	0,31	7,0	LNXT 0904...	○
181148200	032E90090-04-04-032250	4	32	32	250	30	0,78	7,0	LNXT 0904...	○

☉ Stock item | Produto de stock | Itens de stock

○ Available under request | Disponível sobre consulta | Disponible bajo consulta

LNXT 0904... Inserts | Pastilhas | Plaquetas



LNXT-MP



LNXT-LS

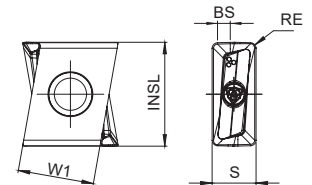

LNXT-MP | LS

		P			M	K			S	Dimensions Dimensões Dimensiones (mm)				
		CVD	PVD		PVD	CVD	PVD		PVD	W1	S	INSL	RE	BS
(2) Grade code		T9	T1	G6	X9	L6	T1	G6	X9					
(1) Geometry code	ISO Reference	PH5740	PHP920	PH7740	PHH930	PH5320	PHP920	PH7740	PHH930					
1112225	LNXT 090404 PNER-MP	☉	☉	☉		☉	☉	☉		9,40	4,50	9,00	0,40	-
1112226	LNXT 090408 PNER-MP	☉	☉	☉		☉	☉	☉		9,40	4,50	9,00	0,80	-
1112868	LNXT 090404 PNER-LS				☉				☉	9,40	4,50	9,00	0,80	-

☉ First choice | Primeira opção | 1ª opción

☉ Stock item | Produto de stock | Itens de stock

○ Available under request | Disponível sobre consulta
Disponível bajo consulta

Insert order code = (1) Geometry Code + (2) Grade Code

SPARE PARTS Acessórios | Repuestos

Cutter DC	Insert Screw	Key (Torx)	Order separately	
			Key (Torx - Nm)	Torque Value
A90090 - 40-63	P0250700	XT07	DT0709	1,2
R90090 - 25-32	P0250700	XT07	DT0709	1,2
W90090 - 16-32	P0250700	XT07	DT0709	1,2
E90090 - 25-32	P0250700	XT07	DT0709	1,2

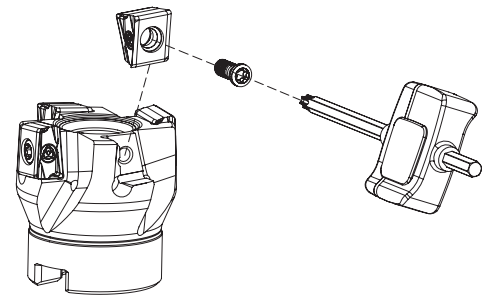

GRADES SELECTION GUIDE Guia para seleção de graus | Tabla para selección de calidades

ISO	PSM	Material	HB (Brinell)	Grades				
				← Wear Resistance			Toughness →	
				PH5320	PHP920	PHH930	PH5740	PH7740
P	1	Unalloyed Steel	125-220	☉	☉	☉	☉	☉
	2	Low-Alloyed Steel	220-280		☉		☉	☉
	3	High-Alloyed Steel	280-380		☉		☉	☉
M	4	SS - Ferritic / Martensitic	200-330			☉		
	5	SS - Austenitic	200-330			☉		
	6	SS - Austenitic-ferritic (Duplex)	230-260			☉		
K	7	Malleable Cast Iron	130-230	☉	☉			☉
	8	Grey Cast Iron	180-245	☉	☉			☉
	9	Nodular Cast iron	160-250	☉	☉			☉
S	11	Heat Resistant Super Alloys	200-320			☉		

☉ Good Conditions

☉ Average Conditions

☉ Difficult Conditions

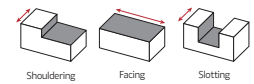

RECOMMENDED CUTTING CONDITIONS Condições de corte recomendadas | Condiciones de corte recomendables

ISO	PSM	Material	HB (Brinell)	Vc (m/min)					Feed fz (mm/t)	
				← Wear Resistance		Toughness →			LNXT 09... MP	LNXT 09... LS
				PH5320	PHP920	PHH930	PHS740	PH7740		
P	1	Unalloyed Steel	125-220	-	180-250	-	140-220	140-200	0,08-0,25	-
	2	Low-Alloyed Steel	220-280	-	160-230	-	120-200	130-180	0,08-0,25	-
	3	High-Alloyed Steel	280-380	-	140-220	-	100-190	100-170	0,08-0,15	-
M	4	SS - Ferritic / Martensitic	200-330	-	-	140-210	-	-	0,08-0,25	0,08-0,25
	5	SS - Austenitic	200-330	-	-	120-170	-	-	0,08-0,20	0,08-0,20
	6	SS - Austenitic-ferritic (Duplex)	230-260	-	-	100-150	-	-	0,08-0,15	0,08-0,20
K	7	Malleable Cast Iron	130-230	150-280	160-270	-	-	140-220	0,08-0,30	-
	8	Grey Cast Iron	180-245	160-320	140-250	-	-	120-210	0,08-0,25	-
	9	Nodular Cast iron	160-250	100-190	120-210	-	-	100-190	0,08-0,20	-
S	11	Heat Resistant Super Alloys	200-320	-	-	30-110	-	-	-	-

(Note 1) Cutting conditions $a_e/D_c=70\%$.

(Note 2) It's possible to occur vibrations in certain cases. Please reduce depth of cut and / or reduce cutting conditions in following cases:

- When using long shank;
- When using long tool overhang with arbor type;
- When application has poor clamping rigidity or when using a low rigidity machine.

CHIP BREAKER SELECTION GUIDE Guia para aplicações do quebra-apanas | Guía para aplicación del rompevirutas

ISO	PSM	Material	HB (Brinell)	Chip breaker application	
				1st choice	
P	1	Unalloyed Steel	125-220	MP	
	2	Low-Alloyed Steel	220-280	MP	
	3	High-Alloyed Steel	280-380	MP	
M	4	SS - Ferritic / Martensitic	200-330	LS	
	5	SS - Austenitic	200-330	LS	
	6	SS - Austenitic-ferritic (Duplex)	230-260	LS	
K	7	Malleable Cast Iron	130-230	MP	
	8	Grey Cast Iron	180-245	MP	
	9	Nodular Cast iron	160-250	MP	
S	11	Heat Resistant Super Alloys	200-320	LS	

TEST REPORT Relatório de Teste | Informe de Prueba

Milling cutter
020W17190-02-06-020100

Insert
ANHX 100405-PNER-LM

Grade
PH7920

39% productivity improvement

Machining time
90 (min/per edge)

palbit
ULTIMATE TOOL SOLUTIONS

Milling cutter
Competitor Equivalent product

Insert
Competitor Equivalent product

Grade
Competitor Equivalent product

Machining time
65 (min/per edge)

COMPETITOR

Work material: 40CrMnNiMo7 (1.2738) - (32-36 HRC)

Cutting speed: Vc (m/min)	180
Feed per tooth: fz (mm/t)	0,2
Depth of cut: ap (mm)	4,0
Width of cut: ae (mm)	25,6
Method of machining	Shoulder milling
Coolant	Dry

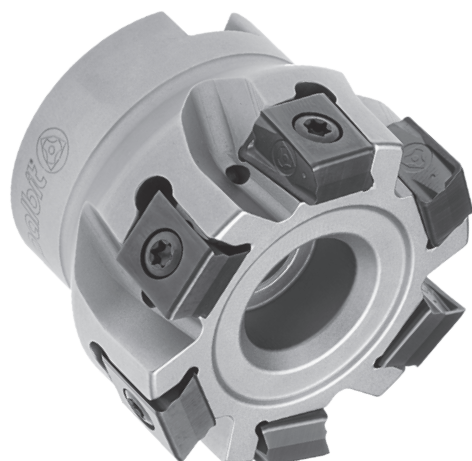

Arbor Mounting
KAPR=90° | GAMP=-4°

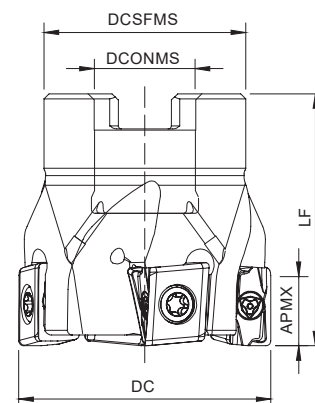

Order code Código	Reference Referência Referencia	CICT	Dimensions Dimensões Dimensiones (mm)				WT	Specifications		Insert Pastilha Inserto	Stock
			DC	DCONMS	DCSFMS	LF		Arbor Type	APMX (mm)		
181118800	040A90190-04-04-016040	4	40	16	32	40	0,17	A	11	LNXT 1306...	⊗
181118900	040A90190-05-04-016040	5	40	16	32	40	0,18	A	11	LNXT 1306...	⊗
181111200	050A90190-05-04-022040	5	50	22	40	40	0,27	A	11	LNXT 1306...	⊗
181111300	050A90190-06-04-022040	6	50	22	40	40	0,28	A	11	LNXT 1306...	⊗
181119000	063A90190-06-04-022040	6	63	22	52	40	0,52	A	11	LNXT 1306...	⊗
181119100	063A90190-08-04-022040	8	63	22	52	40	0,52	A	11	LNXT 1306...	⊗
181119200	080A90190-07-04-027050	7	80	27	60	50	0,88	B	11	LNXT 1306...	⊗
181119300	080A90190-10-04-027050	10	80	27	60	50	0,86	B	11	LNXT 1306...	⊗
181119400	100A90190-09-04-032050	9	100	32	80	50	1,56	B	11	LNXT 1306...	⊗
181119500	100A90190-13-04-032050	13	100	32	80	50	1,56	B	11	LNXT 1306...	⊗
181119600	125A90190-11-04-040063	11	125	40	90	63	2,87	B	11	LNXT 1306...	⊗
181119700	125A90190-16-04-040063	16	125	40	90	63	2,86	B	11	LNXT 1306...	⊗

⊗ Stock item | Produto de stock | Itens de stock

○ Available under request | Disponível sobre consulta | Disponible bajo consulta



Weldon Shank
KAPR=90° | GAMP=-4°

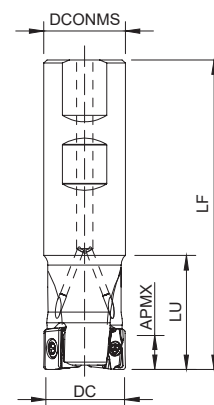

Order code Código	Reference Referência Referencia	CICT	Dimensions Dimensões Dimensiones (mm)				WT	Specifications	Insert Pastilha Inserto	Stock
			DC	DCONMS	LF	LU		APMX (mm)		
181118300	025W90190-02-04-025095	2	25	25	95	45	0,29	11	LNXT 1306...	⊗
181109800	032W90190-03-04-032110	3	32	32	110	50	0,55	11	LNXT 1306...	⊗
181118400	040W90190-04-04-032110	4	40	32	110	50	0,60	11	LNXT 1306...	⊗

⊗ Stock item | Produto de stock | Itens de stock

○ Available under request | Disponível sobre consulta | Disponible bajo consulta

TGPLUS 90190
LNXT 13



Cylindrical Shank
KAPR=90° | GAMP=-4°

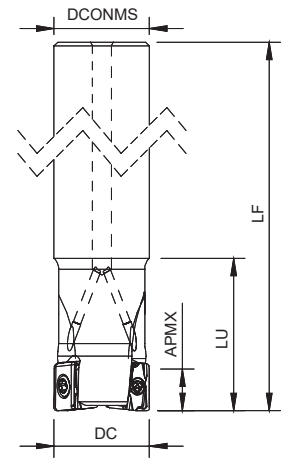

Order code Código	Reference Referência Referencia	CICT	Dimensions Dimensões Dimensiones (mm)				WT	Specifications	Insert Pastilha Inserto	Stock
			DC	DCONMS	LF	LU		APMX (mm)		
181118500	025E90190-02-04-025200	2	25	25	200	40	0,66	11	LNXT 1306...	☼
181118600	032E90190-03-04-032250	3	32	32	250	50	1,37	11	LNXT 1306...	☼
181118700	040E90190-04-04-032250	4	40	32	250	50	1,42	11	LNXT 1306...	☼

☼ Stock item | Produto de stock | Itens de stock

○ Available under request | Disponível sobre consulta | Disponible bajo consulta

LNXT 1306... Inserts | Pastilhas | Plaquetas



LNXT-MP

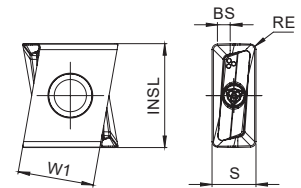

LNXT-MP

		P			M	K			Dimensions Dimensões Dimensiones (mm)				
		CVD	PVD		PVD	CVD	PVD						
		(2) Grade code	T9	T1	G6	G6	L6	T1	G6	W1	S	INSL	RE
(1) Geometry code	ISO Reference	PHS740	PHP920	PH7740	PH7740	PH5320	PHP920	PH7740					
1112242	LNXT 130604 PNER-MP	☼	☼	☼	☼	☼	☼	☼	9,80	6,80	13,00	0,40	0,90
1112243	LNXT 130608 PNER-MP	☼	☼	☼	☼	☼	☼	☼	9,80	6,80	13,00	0,80	0,90

☼ First choice | Primeira opção | 1ª opción

☼ Stock item | Produto de stock | Itens de stock

○ Available under request | Disponível sobre consulta
Disponible bajo consulta

Insert order code = (1) Geometry Code + (2) Grade Code

SPARE PARTS Acessórios | Repuestos

Cutter DC	Insert Screw	Key (Torx)	Order separately		Order separately	
			Key (Torx - Nm)	Torque Value	Screw	DIN 6368 Wrench
E90190 - 25	P0400900	XT15	DT1530	3,0	-	-
E90190 - 32-40	P0401200	XT15	DT1530	3,0	-	-
W90190 - 25	P0400900	XT15	DT1530	3,0	-	-
W90190 - 32-40	P0401200	XT15	DT1530	3,0	-	-
A90190 - 40-63	P0401200	XT15	DT1530	3,0	-	-
A90190 - 80	P0401200	XT15	DT1530	3,0	J0123510	SD6368-12
A90190 - 100	P0401200	XT15	DT1530	3,0	J0164110	SD6368-16
A90190 -125	P0401200	XT15	DT1530	3,0	J0204610	SD6368-20

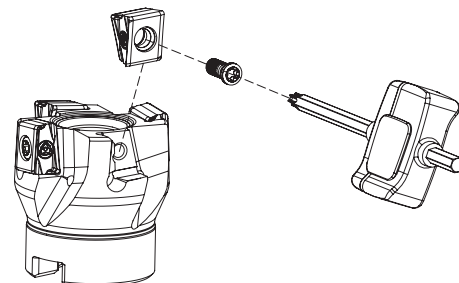

GRADES SELECTION GUIDE Guia para selecção de graus | Tabla para selección de calidades

ISO	PSM	Material	HB (Brinell)	Grades			
				← Wear Resistance			Toughness →
				PH5320	PHP920	PHS740	PH7740
P	1	Unalloyed Steel	125-220	●	●	●	●
	2	Low-Alloyed Steel	220-280		●	●	●
	3	High-Alloyed Steel	280-380		●	●	●
M	4	SS - Ferritic / Martensitic	200-330				●
	5	SS - Austenitic	200-330				●
	6	SS - Austenitic-ferritic (Duplex)	230-260				●
K	7	Malleable Cast Iron	130-230	●	●		●
	8	Grey Cast Iron	180-245	●	●		●
	9	Nodular Cast iron	160-250	●	●		●

● Good Conditions
 ● Average Conditions
 ● Difficult Conditions

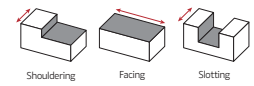

RECOMMENDED CUTTING CONDITIONS Condições de corte recomendadas | Condiciones de corte recomendables

ISO	PSM	Material	HB (Brinell)	Vc (m/min)				Feed fz (mm/t)
				← Wear Resistance		Toughness →		
				PH5320	PHP920	PHS740	PH7740	LNXT 09... MP
P	1	Unalloyed Steel	125-220	-	180-250	140-220	140-200	0,08-0,25
	2	Low-Alloyed Steel	220-280	-	160-230	120-200	130-180	0,08-0,25
	3	High-Alloyed Steel	280-380	-	140-220	100-190	100-170	0,08-0,15
M	4	SS - Ferritic / Martensitic	200-330	-	-	-	130-180	0,08-0,25
	5	SS - Austenitic	200-330	-	-	-	110-160	0,08-0,20
	6	SS - Austenitic-ferritic (Duplex)	230-260	-	-	-	90-150	0,08-0,15
K	7	Malleable Cast Iron	130-230	150-280	160-270	-	140-220	0,08-0,30
	8	Grey Cast Iron	180-245	160-320	140-250	-	120-210	0,08-0,25
	9	Nodular Cast iron	160-250	100-190	120-210	-	100-190	0,08-0,20

(Note 1) Cutting conditions $a_e/D_c=70\%$.

(Note 2) It's possible to occur vibrations in certain cases. Please reduce depth of cut and / or reduce cutting conditions in following cases:

- When using long shank;
- When using long tool overhang with arbor type;
- When application has poor clamping rigidity or when using a low rigidity machine.

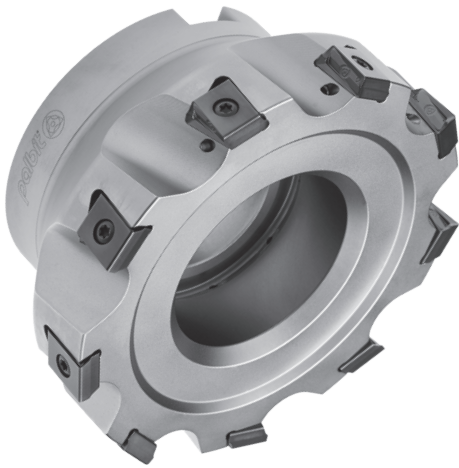

Arbor Mounting
KAPR=90° | GAMP=-5°

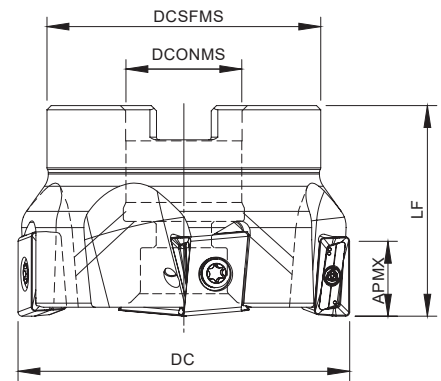

Order code Código	Reference Referência Referencia	CICT	Dimensions Dimensões Dimensiones (mm)				WT	Specifications		Insert Pastilha Inserto	Stock
			DC	DCONMS	DCSFMS	LF		Arbor Type	APMX (mm)		
181069200	050A90390-05-05-022040	5	50	22	40	40	0,315	A	14,0	LNXT 1506...	⊗
181066400	063A90390-05-05-022040	5	63	22	52	40	0,524	A	14,0	LNXT 1506...	⊗
181051000	063A90390-08-05-022040	8	63	22	52	40	0,550	A	14,0	LNXT 1506...	⊗
181066500	080A90390-07-05-027050	7	80	27	60	50	0,936	A	14,0	LNXT 1506...	⊗
181052000	080A90390-10-05-027050	10	80	27	60	50	0,939	B	14,0	LNXT 1506...	⊗
181066600	100A90390-08-05-032050	8	100	32	80	50	1,586	B	14,0	LNXT 1506...	⊗
181051100	100A90390-12-05-032050	12	100	32	80	50	1,690	B	14,0	LNXT 1506...	⊗
181066700	125A90390-09-05-040063	9	125	40	90	63	3,001	B	14,0	LNXT 1506...	⊗
181051200	125A90390-15-05-040063	15	125	40	90	63	3,113	B	14,0	LNXT 1506...	⊗
181051300	160A90390-10-05-U040063	10	160	40	110	63	4,470	C	14,0	LNXT 1506...	⊗
181066800	160A90390-20-05-U040063	20	160	40	110	63	4,580	C	14,0	LNXT 1506...	⊗

⊗ Stock item | Produto de stock | Itens de stock

○ Available under request | Disponível sobre consulta | Disponible bajo consulta

SPARE PARTS Acessórios | Repuestos

Cutter DC	Insert Screw	Key (Torx)	Order separately		Order separately	
			Key (Torx - Nm)	Torque Value	Screw	DIN 6368 Wrench
A90390 - 50 - 80	P0401200	XT15	DT1530	3,0	-	-
A90390 - 80	P0401200	XT15	DT1530	3,0	J0123510	SD6368-12
A90390 - 100	P0401200	XT15	DT1530	3,0	J0164110	SD6368-16
A90390 - 125	P0401200	XT15	DT1530	3,0	J0204610	SD6368-20
A90390 - 160	P0401200	XT15	DT1530	3,0	-	-

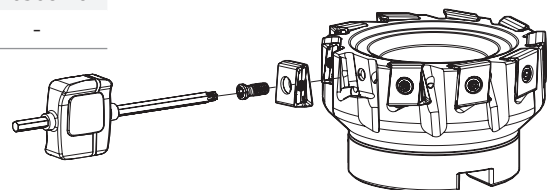

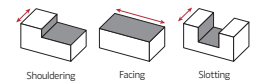

LNXT 1506... Inserts | Pastilhas | Plaquetas



LNXT-HP



LNXT-MP



LNXT-W

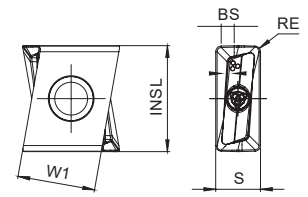

LNXT - MP | HP

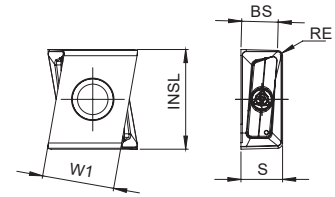

LNXT-W

		P					K					Dimensions Dimensões Dimensiones (mm)					
		CVD	PVD				CVD		PVD								
(2) Grade code		T9	G1	G4	T1	G6	L5	L9	G1	G4	T1	G6	W1	S	INSL	RE	BS
(1) Geometry code	ISO Reference	PH5740	PH7910	PH7920	PHP920	PH7740	PH5705	PH5740	PH7910	PH7920	PHP920	PH7740					
1111313	LNXT 150608 PNER-MP	⊗	⊗	⊗	⊗	⊗	⊗	⊗	⊗	⊗	⊗	⊗	11,00	6,35	15,00	0,80	1,80
1111590	LNXT 150612 PNER-MP			⊗	⊗	⊗	⊗	⊗		⊗	⊗	⊗	11,00	6,35	15,00	1,20	1,80
1111591	LNXT 150608 PNSR-HP			⊗		⊗				⊗		⊗	11,00	6,35	15,00	0,80	1,80
1111524	LNXT 150608 PNER-W		⊗				⊗		⊗				11,00	6,35	15,20	0,80	5,50

⊗ First choice | Primeira opção | 1ª opción

⊗ Stock item | Produto de stock | Itens de stock

○ Available under request | Disponível sobre consulta
Disponível bajo consulta

Insert order code = (1) Geometry Code + (2) Grade Code

GRADES SELECTION GUIDE Guia para selecção de graus | Tabla para selección de calidades

ISO	PSM	Material	HB (Brinell)	Grades						
				← Wear Resistance				Toughness →		
				PH5705	PH7910	PHP920	PH7920	PH5740	PHS740	PH7740
P	1	Unalloyed Steel	125-220		✓	✓	✓		✓	✓
	2	Low-Alloyed Steel	220-280		✓	✓	✓		✓	✓
	3	High-Alloyed Steel	280-380		✓	✓	✓		✓	✓
K	7	Malleable Cast Iron	130-230	✓	✓	✓	✓	✓		✓
	8	Grey Cast Iron	180-245	✓	✓	✓	✓	✓		✓
	9	Nodular Cast iron	160-250	✓	✓	✓	✓	✓		✓

● Good Conditions

● Average Conditions

● Difficult Conditions

RECOMMENDED CUTTING CONDITIONS Condições de corte recomendadas | Condiciones de corte recomendables

ISO	PSM	Material	HB (Brinell)	Vc (m/min)						
				← Wear Resistance					Toughness →	
				PH5705	PH7910	PHP920	PH7920	PH5740	PH5740	PH7740
P	1	Unalloyed Steel	125-220	-	180-250	180-250	180-240	-	140-220	140-200
	2	Low-Alloyed Steel	220-280	-	160-230	160-230	160-220	-	120-200	130-180
	3	High-Alloyed Steel	280-380	-	140-220	140-220	140-210	-	100-190	100-170
K	7	Malleable Cast Iron	130-230	160-290	180-300	160-270	160-260	160-260	-	140-220
	8	Grey Cast Iron	180-245	170-320	160-250	140-250	140-240	140-240	-	120-210
	9	Nodular Cast iron	160-250	140-200	150-200	120-210	120-200	120-200	-	100-190

ISO	PSM	Material	HB (Brinell)	Feed fz (mm/t)		
				LNXT 15... MP	LNXT 15... HP	LNXT 15... W
P	1	Unalloyed Steel	125-220	0,10-0,30	0,10-0,30	0,10-0,35
	2	Low-Alloyed Steel	220-280	0,10-0,30	0,10-0,30	0,10-0,35
	3	High-Alloyed Steel	280-380	0,10-0,25	0,10-0,25	0,10-0,35
K	7	Malleable Cast Iron	130-230	0,10-0,40	0,10-0,40	0,10-0,50
	8	Grey Cast Iron	180-245	0,10-0,35	0,10-0,35	0,10-0,50
	9	Nodular Cast iron	160-250	0,10-0,30	0,10-0,30	0,10-0,50

(Note 1) Cutting conditions $a_e/D_c=70\%$.

(Note 2) It's possible to occur vibrations in certain cases. Please reduce depth of cut and / or reduce cutting conditions in following cases:

- When using long shank;
- When using long tool overhang with arbor type;
- When application has poor clamping rigidity or when using a low rigidity machine.

CHIP BREAKER SELECTION GUIDE Guia para aplicações do quebra- aparas | Guía para aplicación del rompevirutas

ISO	PSM	Material	HB (Brinell)	Chip breaker application	
				1st choice	Difficult Operations
P	1	Unalloyed Steel	125-220	LNXT 15... MP	LNXT 15... HP
	2	Low-Alloyed Steel	220-280	LNXT 15... MP	LNXT 15... HP
	3	High-Alloyed Steel	280-380	LNXT 15... MP	LNXT 15... HP
K	7	Malleable Cast Iron	130-230	LNXT 15... MP	LNXT 15... HP
	8	Grey Cast Iron	180-245	LNXT 15... MP	LNXT 15... HP
	9	Nodular Cast iron	160-250	LNXT 15... MP	LNXT 15... HP

WIPER INSERTS

Rec. Cutting Conditions

- F_w at least 40% larger than f_r ($f_r - f_2 \times Z$);
- Axial depth of cut is 0,5 - 0,8mm.

Example:

- The width of the parallel land (F) of the insert is 1,8mm
- With a cutter of 10 inserts and using a feed per tooth (f_z) of 0,3mm, the feed per revolution (f_r) will be 3mm, i.e. 40% bigger than the parallel land.
- To obtain a good surface finish, the feed per revolution should be a maximum of 80% of 1,8mm = 1,44mm.
- The wiper insert will have a parallel land (F_w) with a width of approximately 5,5mm.
- Result: Feed per revolution (f_r) could be increased from 0,8mm to 60% of 5,5mm = 3,3mm.

Note: Other limitations, such as machine power, must be taken into consideration.

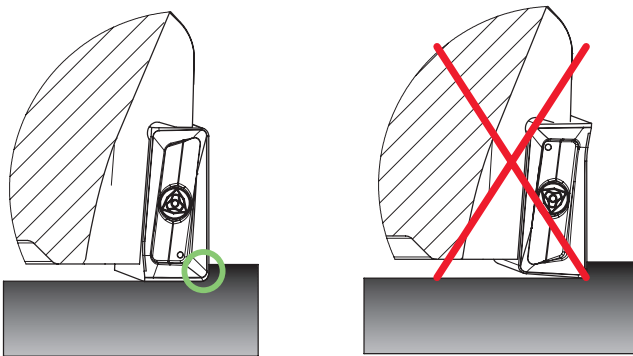

The points on the insert indicates the side that should be parallel to the workspace material.

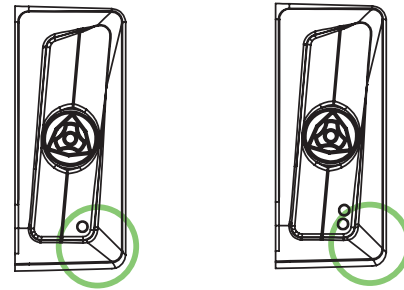

Wiper insert with 2 Right-hand cutting edges.
The side work of the insert it's indicated by points.

90090 | 90190 | 90390

TGPLUS

High performance on tangential shoulder milling



Check the QrCode for more information



HEADQUARTERS

PALBIT. S.A.

T (+351) 234 540 300 | F (+351) 234 540 301

palbit@palbit.pt | www.palbit.pt

Branch office

PALBIT México, S de RL de CV

T (+52) 5555 454 543 | F (+52) 5552 509 190

info@palbit.com.mx | www.palbit.pt/mx

Branch office

PALBIT Brasil

T (+55) 011 25 343 648

palbit@palbit.com.br | www.palbit.pt/br