

72090

HARDMILL

High performance cutting with PCD inserts

MILLING

Facing | Shoudering



HARDMILL 72090



Arbor Mounting
KAPR=90° | GAMP=0°

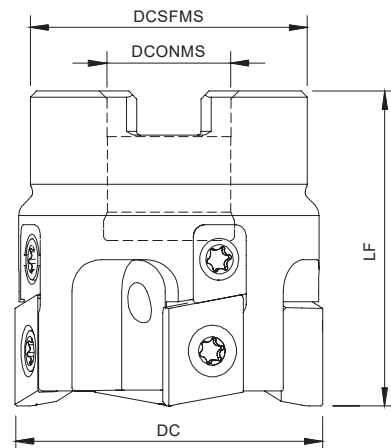

Order code Código	Reference Referência Referencia	CICT	Dimensions Dimensões Dimensiones (mm)				WT	Specifications		Insert Pastilha Inserto	Stock
			DC	DCONMS	DCSFMS	LF		Arbor Type	RPM max		
181129700	040A72090-04-016040	4	40	16	36	40	0,32	A	32 000	XNHW 1205...	☺
181129800	050A72090-04-022040	4	50	22	46	40	0,38	A	32 000	XNHW 1205...	☺
181129900	050A72090-05-022040	5	50	22	46	40	0,37	A	32 000	XNHW 1205...	○
181130000	063A72090-04-022040	4	63	22	49	40	0,65	A	29 000	XNHW 1205...	○
181130100	063A72090-07-022040	7	63	22	49	40	0,62	A	29 000	XNHW 1205...	☺
181130200	080A72090-05-027050	5	80	27	60	50	1,25	A	26 000	XNHW 1205...	☺
181130300	080A72090-09-027050	9	80	27	60	50	1,17	A	26 000	XNHW 1205...	☺
181130400	100A72090-06-032050	6	100	32	70	50	1,93	A	24 000	XNHW 1205...	☺
181130500	100A72090-12-032050	12	100	32	70	50	1,80	A	24 000	XNHW 1205...	○
181130600	125A72090-08-040063	8	125	40	72	63	2,88	A	22 000	XNHW 1205...	○
181130700	125A72090-14-040063	14	125	40	72	63	2,60	A	22 000	XNHW 1205...	○
181135500	160A72090-10-040063	10	160	40	72	63	3,30	A	18 000	XNHW 1205...	○
181135600	160A72090-16-040063	16	160	40	118	63	5,45	A	18 000	XNHW 1205...	○

SPARE PARTS Acessórios | Repuestos

Cutter DC	Insert Screw	Key (Torx)	Order separately		
			Key (Torx - Nm)	Torque Value	Wedge
A72090 - 40-160	P0401100	XT15	DT1530	3,00	SETDEV AS 04 00

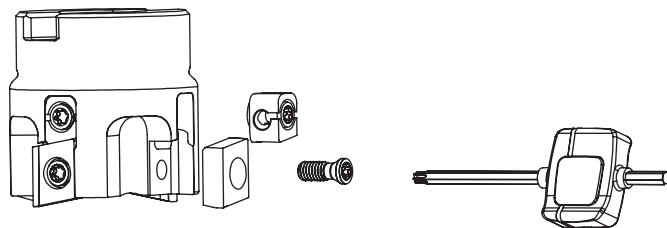

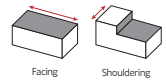

XNHW 1205... Inserts | Pastilhas | Plaquetas

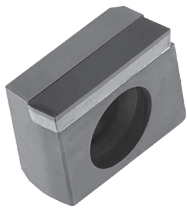

XNHW 1205 PZFR-020120

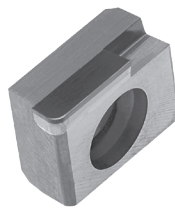

XNHW 120508 PZTR-000080

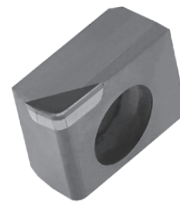

XNHW 120508 PZTR-015045

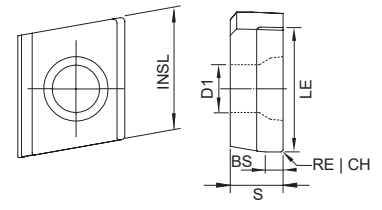

XNHW

		N		Dimensions Dimensões Dimensiones (mm)								
		PCD		INSL	S	LE	D1	RE	CHW	KCH	BS	
(2) Grade code	I3	D6										
(1) Geometry code	ISO Reference	PDP403	PDP410									
1112564	XNHW 120504 PZFR-015045	○	○	12,25	5,40	4,50	4,80	0,40	-	-	1,50	
1112565	XNHW 120504 PZFR-000080	○	○	12,25	5,40	8,00	4,80	0,40	-	-	-	
1112566	XNHW 120508 PZFR-015045	⊗	○	12,25	5,40	4,50	4,80	0,80	-	-	1,50	
1112551	XNHW 120508 PZTR-015045	⊗	○	12,25	5,40	4,50	4,80	0,80	-	-	1,50	
1112552	XNHW 120508 PZTR-000080	○	○	12,25	5,40	8,00	4,80	0,80	-	-	-	
1112553	XNHW 1205 PZFR-020120	⊗	○	12,25	5,40	12,00	4,80	-	0,20	45°	2,00	
1112567	XNHW 1205 PZFR-030045	○	○	12,25	5,40	4,50	4,80	-	0,20	45°	3,00	
1112568	XNHW 1205 PZTR-030045	○	○	12,25	5,40	4,50	4,80	-	0,20	45°	3,00	

INSERTS CODIFICATION SYSTEM Sistema de codificação de pastilhas | Sistema de codificación de insertos

ISO CODE	Insert size	Insert thickness	Insert radius	Cutting edge position angle	Cutting edge relief angle	Cutting edge conditions	Cut direction	Wiper edge length	Máx. Ap	
XNHW	12	05	04	P	Z	F	R	-	015	030

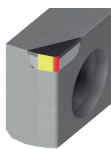

XNHW 120504 PZFR-0150045

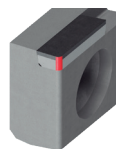

XNHW 120504 PZFR-000080

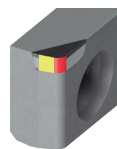

XNHW 120508 PZFR-015045

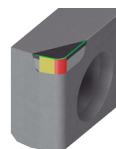

XNHW 120508 PZTR-015045

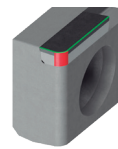

XNHW 120508 PZTR-000080

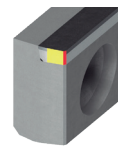

XNHW 1205 PZFR-020120

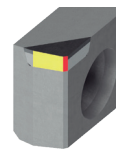

XNHW 1205 PZFR-030045

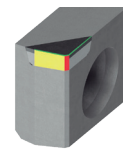

XNHW 1205 PZTR-030045

■ Cutting edge Type (radius, chamfer)

■ Wiper cutting edge

■ Edge Preparation (F, T)

RECOMMENDED CUTTING CONDITIONS Condições de corte recomendadas | Condiciones de corte recomendables

ISO	Material		HB (Brinell)	Vc (m/min)	Feed fz (mm/t)
	Work piece material	Type of treatment / alloy		PDP403	XNHW 12...
N	Aluminium wrought alloys		80	300 - 4000	0,05 - 0,40
			90	300 - 1500	
		< 12% Si	130	300 - 5000	
	Aluminium cast alloys	< 12% Si	90	300 - 3000	
		> 12% Si	100	300 - 1000	
		brass, red bronze	100	100 - 700	
	Non-ferrous materials	bronze	-	100 - 1500	
		lead-free copper and electrolytic copper	-	300 - 3000	
		thermosetting plastics	-	80 - 300	
		fibre-reinforced plastics	200-320	80 - 300	
Non-metallic materials	hard rubber		80 - 300		

72090

HARDMILL

High performance cutting with PCD inserts



Check the QrCode for more information



HEADQUARTERS

PALBIT. S.A.

T (+351) 234 540 300 | F (+351) 234 540 301

palbit@palbit.pt | www.palbit.pt

Branch office

PALBIT México, S de RL de CV

T (+52) 5555 454 543 | F (+52) 5552 509 190

info@palbit.com.mx | www.palbit.pt/mx

Branch office

PALBIT Brasil

T (+55) 011 25 343 648

palbit@palbit.com.br | www.palbit.pt/br