

# MASTER GROOVING

Precision & versatility for grooving operations

palbit 

GROOVING



SINCE 1916

# MASTER GROOVING

The Master Grooving line is the latest grooving solution, engineered to ensure exceptional accuracy, stability, and reliability in the most demanding grooving and parting-off operations.

This comprehensive range, including grooving inserts, toolholders, blades, and complementary accessories, is designed to deliver superior chip control, extended tool life, and consistent dimensional precision.

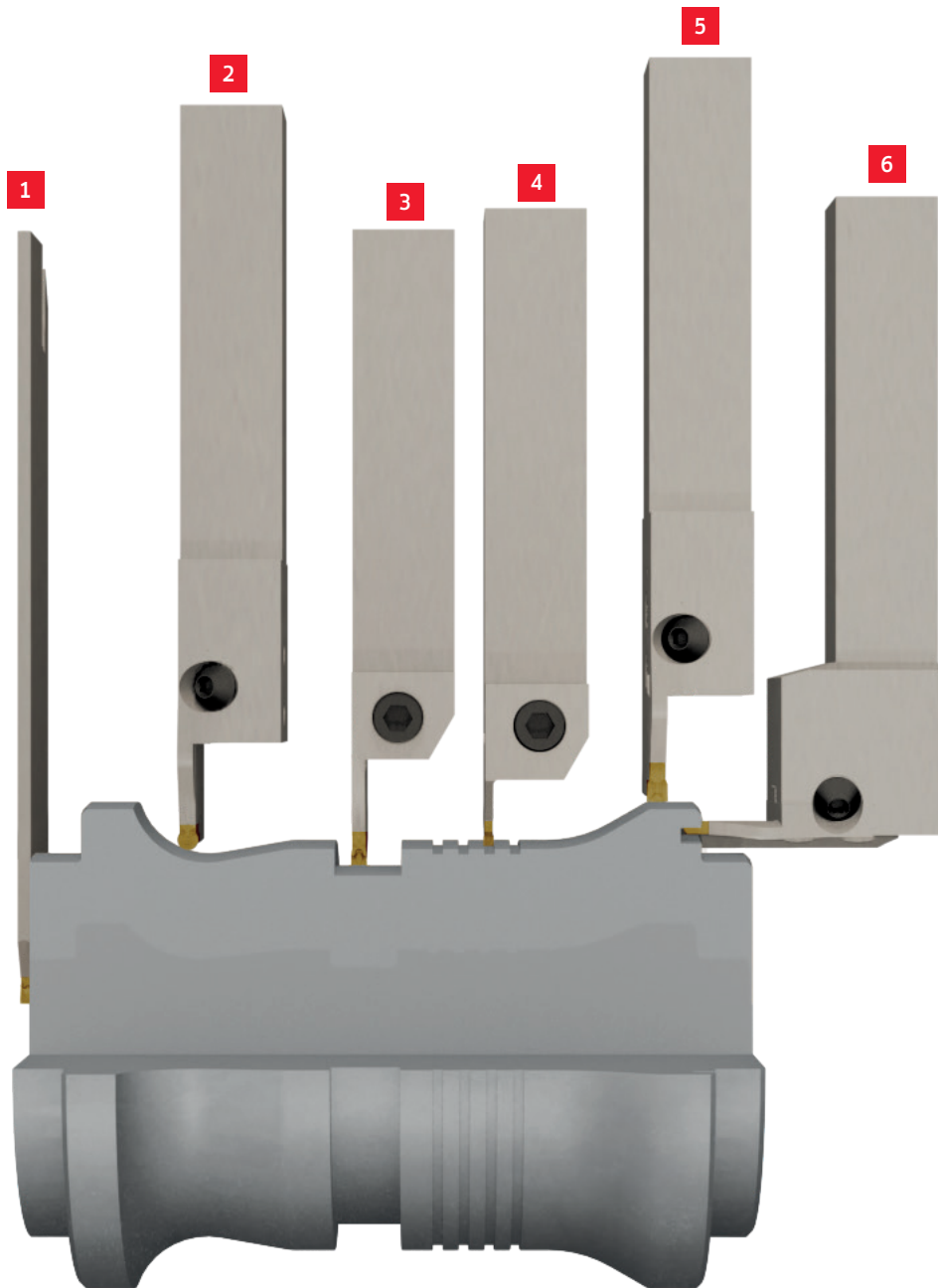

## MASTER GROOVING OPERATIONS

### Blades

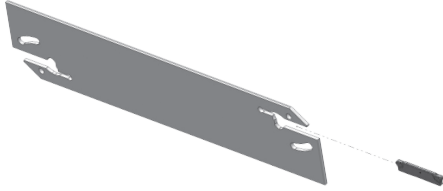

- 1 Parting Off

### Monoblock System

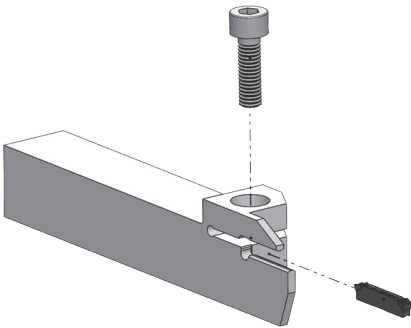

- 3 Deep Grooving
- 4 Light Grooving

### Modular System

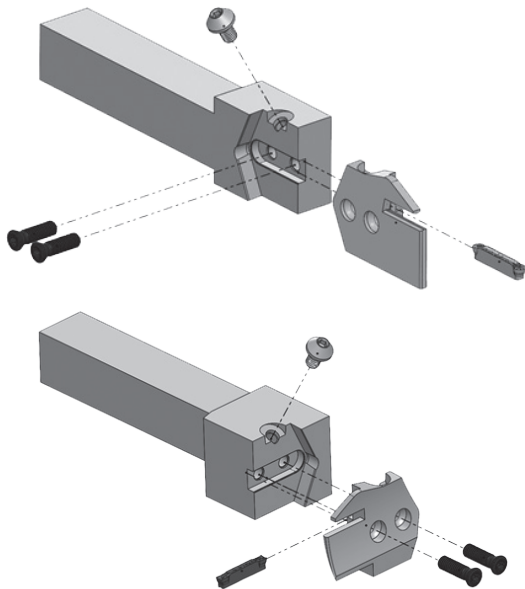

- 2 Profiling
- 5 Groove Turning
- 6 Face Grooving

Check the QrCode to watch the full video



# MASTER GROOVING

Maximize grooving performance with our robust toolholder range, from monoblock designs to modular systems, including PSC setups and face grooving cartridges.

Engineered to support several insert geometries, these holders deliver flexible, high-precision solutions across a wide spectrum of materials and operations.



MONOBLOCK SYSTEM

Toolholders



PSC Toolholders

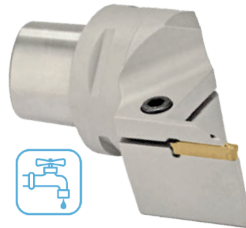

Blades



- **High Rigidity:** One-piece design for maximum stability and accuracy.
- **Compact and Stable Design:** Solid, interface-free design ensures high stability and excellent vibration damping.
- **Quick and Reliable Insert Clamping:** Rigid clamping for precise and quick insert changes.
- **Chip and Thermal Control:** Possibility to select PSC systems with internal coolant, for extended tool life.

MODULAR SYSTEM

Toolholders

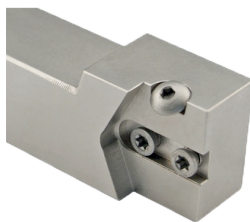

PSC Toolholders



Cartridges

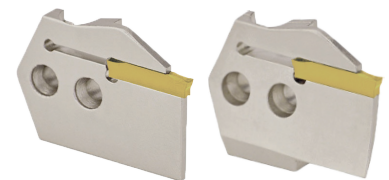

- **Flexible system:** Interchangeable components adapt easily to several machines, inserts, and applications.
- **Reduced Tool Inventory:** A single base holder can be combined with multiple cartridges, minimizing the need for separate tools.
- **Quick Changeover:** Fast and repeatable tool changes reduce machine downtime and improve overall productivity.
- **Long-Term Cost-Efficient :** Modular design reduces overall tooling expenses over time.
- **Compatible with Modern Interfaces:** Available for PSC systems.

**Master Grooving** inserts deliver high-performance machining through advanced chipbreaker designs and PHL coating.

Engineered for precision and durability, they ensure excellent chip control, reduced cutting forces, and extended tool life across a wide range of grooving operations and materials.

## 5 CHIPBREAKER GEOMETRIES FOR MAXIMUM EFFICIENCY

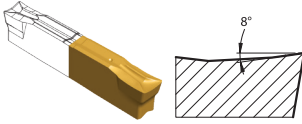
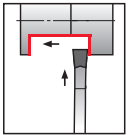
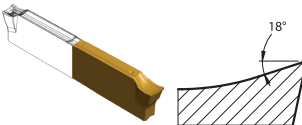
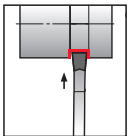
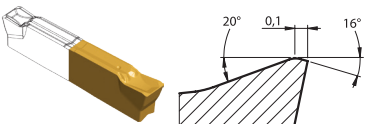
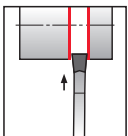
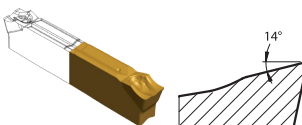
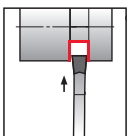
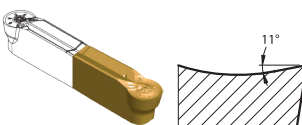
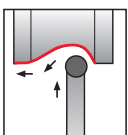
Chipbreaker	Specifications		Material	Properties	Main application
	Cutting edges	Insert width (mm)			
<b>-UG</b> 	1	1,5 2,0 3,0	<span style="background-color: #0070C0; color: white; padding: 2px;">P</span> <span style="background-color: #DC143C; color: white; padding: 2px;">K</span>	Recommended for machining several material types, true universal grooving performance; Designed for both grooving and turning applications; Consistent and efficient chip control.	 Groove Turning
		4,0 5,0 6,0			
<b>-LG</b> 	1	1,5 2,0 3,0	<span style="background-color: #0070C0; color: white; padding: 2px;">P</span> <span style="background-color: #DC143C; color: white; padding: 2px;">K</span>	Sharp cutting geometry for lower cutting forces; Optimized to reduce built-up edge formation, even in low-feed applications; Well-suited for thin-walled components.	 Light Grooving
		4,0 5,0 6,0			
<b>-CG</b> 	1	1,5 2,0 3,0	<span style="background-color: #0070C0; color: white; padding: 2px;">P</span> <span style="background-color: #DC143C; color: white; padding: 2px;">K</span>	Designed with a negative chamfer for increased edge toughness; Handles interrupted cuts even on materials with high strength; First choice for parting off operations.	 Parting Off
		4,0 5,0 6,0			
<b>-MG</b> 	1	1,5 2,0 3,0	<span style="background-color: #FFD700; color: black; padding: 2px;">M</span> <span style="background-color: #FFA500; color: black; padding: 2px;">S</span>	Ideal for stainless steel machining; Sharp geometry for smooth cutting; Optimized to reduce built-up edge formation, even in low-feed applications.	 General Grooving
		4,0 5,0 6,0			
<b>-PG</b> 	1	1,5 2,0 3,0	<span style="background-color: #0070C0; color: white; padding: 2px;">P</span> <span style="background-color: #DC143C; color: white; padding: 2px;">K</span>	Versatile chip breaker adapts to varying depths of cut and feed rates; Round-profile geometry that ensures smooth contouring for accurate profiles; Low cutting forces reduce tool deflection during profiling.	 Profiling
		4,0 5,0 6,0			

Choose your chipbreaker:

Chipbreaker	Specifications			
	Grooving		Turning	Parting Off
	External	Face	External	
<b>-UG</b>	●	●	●	○
<b>-LG</b>	●	●		
<b>-CG</b>	○	○		●
<b>-MG</b>	●	●		●
<b>-PG</b>			●	

● Recommended    ○ Suitable



# MG INSERTS CODE KEY

Chave de codificação para pastilhas MG | Llave de codificación para plaquitas MG

For R or L Insert type

<b>MG</b>	<b>0300</b>	<b>B</b>	<b>020</b>	-	<b>050</b>	<b>R</b>	<b>02</b>	-	<b>MG</b>
<b>1</b>	<b>2</b>	<b>3</b>	<b>4</b>		<b>5</b>	<b>6</b>	<b>7</b>		<b>8</b>

For N Insert type

<b>MG</b>	<b>0300</b>	<b>B</b>	<b>020</b>	-	<b>N</b>	<b>02</b>	-	<b>MG</b>
<b>1</b>	<b>2</b>	<b>3</b>	<b>4</b>		<b>6</b>	<b>7</b>		<b>8</b>

## 1 - Product Line

MG - Master Grooving

## 2 - Cutting Width

0200 - 2,00mm | 0300 - 3,00mm | 0400 - 4,00mm | 0500 - 5,00mm | 0600 - 6,00mm

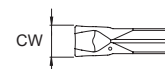

## 3 - Seat Size

A - MG0200 | B - MG0300 | C - MG0400 | D - MG0500 | E - MG0600

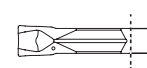

## 4 - Cutting Radius

020 - 0,20mm | 025 - 0,25mm | 040 - 0,40mm | 600 - 6,00mm

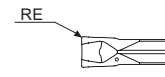

## 5 - Relief Angle (Suppressed on Neutral inserts)

040 - 4° | 060 - 6° | 150 - 15°

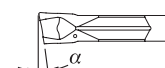

## 6 - Insert Type



## 7 - Number of Cutting Edges



## 8 - Chipbreaker

CG - Cutting Grooving | UG - Universal Grooving | MG - Medium Grooving | LG - Light Grooving | PG - Profiling Grooving

**MG...02-UG** Multifunctional Grooving

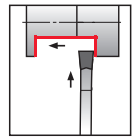
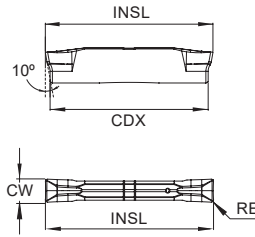

(1) Geometry code	(2) Grade code	P			K			M			S			Dimensions Dimensões Dimensiones (mm)					Cutting conditions Condições de corte Condiciones de corte					
		PVD			PVD			PVD			PVD			CW	RE	INSL	CDX	Seat <sup>2</sup> Size	AP (mm)	Min	Max	fn (mm/r)	Min	Max
		6F	5C	3B	6F	5C	3B	6F	5C	3B	6F	5C	3B											
PHL910	PHL920	PHL930	PHL910	PHL920	PHL930	PHL910	PHL920	PHL930	PHL910	PHL920	PHL930	PHL910	PHL920	PHL930										
1130844	MG0200A020-N02-UG	⊗	⊗		⊗	⊗		⊗	⊗		⊗	⊗		2,00	0,20	22,0	20,0	A	0,50	0,20	0,80	0,08	0,03	0,12
1130828	MG0300B030-N02-UG		⊗	⊗		⊗	⊗		⊗	⊗		⊗	⊗	3,00	0,30	22,0	20,0	B	1,00	0,30	1,70	0,15	0,05	0,25
1130885	MG0400C020-N02-UG		○	○		○	○		○	○		○	○	4,00	0,20	25,0	23,0	C	1,50	0,20	2,70	0,1	0,05	0,15
1130845	MG0400C040-N02-UG		⊗	⊗		⊗	⊗		⊗	⊗		⊗	⊗	4,00	0,40	25,0	23,0	C	1,60	0,40	2,70	0,18	0,08	0,28
1130886	MG0400C080-N02-UG		○	○		○	○		○	○		○	○	4,00	0,80	25,0	23,0	C	1,50	0,20	2,70	0,14	0,05	0,22
1130846	MG0500D040-N02-UG		⊗	⊗		⊗	⊗		⊗	⊗		⊗	⊗	5,00	0,40	25,0	23,0	D	1,80	0,40	3,10	0,17	0,08	0,25
1130887	MG0500D080-N02-UG		○	○		○	○		○	○		○	○	5,00	0,80	25,0	23,0	D	1,80	0,50	3,10	0,14	0,06	0,22
1130847	MG0600E040-N02-UG		⊗	⊗		⊗	⊗		⊗	⊗		⊗	⊗	6,00	0,40	25,0	23,0	E	1,80	0,40	3,20	0,19	0,10	0,28
1130888	MG0600E080-N02-UG		○	○		○	○		○	○		○	○	6,00	0,80	25,0	23,0	E	1,90	0,60	3,20	0,19	0,10	0,28

⊗ First choice | Primeira opção | 1ª opción  
2 - Correspond to a Specific Holder

⊗ Stock item | Produto de stock | Itens de stock

○ Available under request | Disponível sobre consulta  
Disponível bajo consulta

Insert order code = (1) Geometry Code + (2) Grade Code

**MG...02-LG** Light Grooving

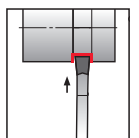
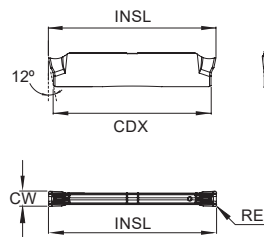

(1) Geometry code	(2) Grade code	P			K			M			S			Dimensions Dimensões Dimensiones (mm)					Cutting conditions Condições de corte Condiciones de corte			
		PVD			PVD			PVD			PVD			CW	RE	INSL	PSIRR/L	CDX	Seat <sup>2</sup> Size	fn (mm/r)	Min	Max
		6F	5C	3B	6F	5C	3B	6F	5C	3B	6F	5C	3B									
PHL910	PHL920	PHL930	PHL910	PHL920	PHL930	PHL910	PHL920	PHL930	PHL910	PHL920	PHL930	PHL910	PHL920	PHL930								
1130853	MG0200A020-N02-LG	⊗	⊗		⊗	⊗		⊗	⊗		⊗	⊗		2,00	0,20	22,0	-	20,0	A	0,07	0,03	0,10
1130921	MG0200A020-150R02-LG	○	○		○	○		○	○		○	○		2,00	0,20	22,0	15,0	20,0	A	0,06	0,03	0,08
1130922	MG0200A020-150L02-LG	○	○		○	○		○	○		○	○		2,00	0,20	22,0	15,0	20,0	A	0,06	0,03	0,08

⊗ First choice | Primeira opção | 1ª opción  
2 - Correspond to a Specific Holder

⊗ Stock item | Produto de stock | Itens de stock

○ Available under request | Disponível sobre consulta  
Disponível bajo consulta

Insert order code = (1) Geometry Code + (2) Grade Code

## MG...01-CG Parting Off

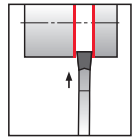
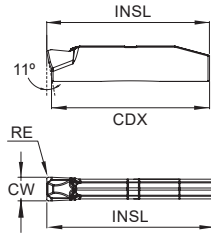

(1) Geometry code	(2) Grade code	P			K			Dimensions Dimensões Dimensiones (mm)					Cutting conditions Condições de corte Condiciones de corte			
		PVD			PVD			CW	RE	INSL	PSIRR/L	Seat <sup>2</sup> Size	fn (mm/r)	Min	Max	
		6F	5C	3B	6F	5C	3B									
		PHL910	PHL920	PHL930	PHL910	PHL920	PHL930									
1130889	MG0200A020-N01-CG	⊗	⊗		⊗	⊗		2,00	0,20	22,0	-	A	0,09	0,03	0,14	
1130849	MG0300B020-N01-CG		⊗	⊗	⊗	⊗		3,00	0,20	22,0	-	B	0,13	0,06	0,20	
1130890	MG0300B020-060R01-CG		⊗	⊗	⊗	⊗		3,00	0,20	22,0	6,0	B	0,11	0,06	0,16	
1130891	MG0300B020-060L01-CG		⊗	⊗	⊗	⊗		3,00	0,20	22,0	6,0	B	0,11	0,06	0,16	
1130892	MG0400C030-N01-CG		○	○		○	○	4,00	0,30	25,0	-	C	0,16	0,08	0,24	
1130893	MG0400C030-040R01-CG		○	○		○	○	4,00	0,30	25,0	4,0	C	0,14	0,06	0,22	
1130894	MG0400C030-040L01-CG		○	○		○	○	4,00	0,30	25,0	4,0	C	0,14	0,06	0,22	
1130895	MG0500D030-N01-CG		⊗	⊗		⊗	⊗	5,00	0,30	25,0	-	D	0,18	0,08	0,28	

⊗ First choice | Primeira opção | 1ª opción    
 ⊗ Stock item | Produto de stock | Itens de stock    
 ○ Available under request | Disponível sobre consulta | Disponible bajo consulta    
 Insert order code = (1) Geometry Code + (2) Grade Code  
⊗ Stock available soon | Produto de stock disponível brevemente | Producto en stock disponible en breve  
 2 - Correspond to a Specific Holder

## MG...02-CG Parting Off

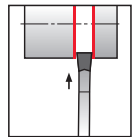
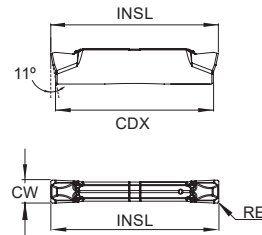

(1) Geometry code	(2) Grade code	P			K			Dimensions Dimensões Dimensiones (mm)					Cutting conditions Condições de corte Condiciones de corte			
		PVD			PVD			CW	RE	INSL	PSIRR/L	CDX	Seat <sup>2</sup> Size	fn (mm/r)	Min	Max
		6F	5C	3B	6F	5C	3B									
		PHL910	PHL920	PHL930	PHL910	PHL920	PHL930									
1130850	MG0200A020-N02-CG	⊗	⊗		⊗	⊗		2,00	0,20	22,0	-	20,0	A	0,09	0,03	0,14
1130896	MG0200A015-060R02-CG	○	○		○	○		2,00	0,15	22,0	6,0	20,0	A	0,08	0,04	0,12
1130897	MG0200A015-060L02-CG	○	○		○	○		2,00	0,15	22,0	6,0	20,0	A	0,08	0,04	0,12
1130898	MG0200A020-150R02-CG	⊗	⊗		⊗	⊗		2,00	0,20	22,0	15,0	20,0	A	0,07	0,03	0,10
1130899	MG0200A020-150L02-CG	⊗	⊗		⊗	⊗		2,00	0,20	22,0	15,0	20,0	A	0,07	0,03	0,10
1130851	MG0300B020-N02-CG		⊗	⊗		⊗	⊗	3,00	0,20	22,0	-	20,0	B	0,13	0,06	0,20
1130900	MG0300B015-060R02-CG		⊗	⊗		⊗	⊗	3,00	0,15	22,0	6,0	20,0	B	0,11	0,06	0,16
1130901	MG0300B015-060L02-CG		⊗	⊗		⊗	⊗	3,00	0,15	22,0	6,0	20,0	B	0,11	0,06	0,16
1130869	MG0400C020-N02-CG		⊗	⊗		⊗	⊗	4,00	0,20	25,0	-	23,0	C	0,16	0,08	0,24
1130902	MG0400C030-N02-CG		○	○		○	○	4,00	0,30	25,0	-	23,0	C	0,16	0,08	0,24
1130903	MG0400C020-040R02-CG		○	○		○	○	4,00	0,20	25,0	4,0	23,0	C	0,14	0,06	0,22
1130904	MG0400C020-040L02-CG		○	○		○	○	4,00	0,20	25,0	4,0	23,0	C	0,14	0,06	0,22
1130852	MG0500D040-N02-CG		⊗	⊗		⊗	⊗	5,00	0,40	25,0	-	23,0	D	0,18	0,08	0,28
1130905	MG0600E040-N02-CG		○	○		○	○	6,00	0,40	25,0	-	23,0	E	0,20	0,10	0,30

⊗ First choice | Primeira opção | 1ª opción    
 ⊗ Stock item | Produto de stock | Itens de stock    
 ○ Available under request | Disponível sobre consulta | Disponible bajo consulta    
 Insert order code = (1) Geometry Code + (2) Grade Code  
⊗ Stock available soon | Produto de stock disponível brevemente | Producto en stock disponible en breve  
 2 - Correspond to a Specific Holder

**MG...01-MG** Stable Grooving

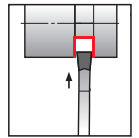
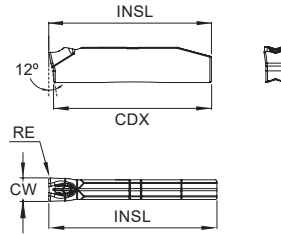

(1) Geometry code	(2) Grade code	M			S			Dimensions Dimensões Dimensiones (mm)					Cutting conditions Condições de corte Condiciones de corte		
		PVD			PVD			CW	RE	INSL	PSIRR/L	Seat <sup>2</sup> Size	fn (mm/r)	Min	Max
		6F	5C	3B	6F	5C	3B								
		PHL910	PHL920	PHL930	PHL910	PHL920	PHL930								
1130841	MG0300B020-N01-MG	⊗	⊗	⊗	⊗	⊗	⊗	3,00	0,20	22,00	-	B	0,15	0,08	0,22
1130906	MG0300B020-060R01-MG	⊗	⊗	⊗	⊗	⊗	⊗	3,00	0,20	22,00	6,00	B	0,11	0,05	0,16
1130907	MG0300B020-060L01-MG	⊗	⊗	⊗	⊗	⊗	⊗	3,00	0,20	22,00	6,00	B	0,11	0,05	0,16
1130908	MG0400C040-N01-MG	○	○	○	○	○	○	4,00	0,40	25,00	-	C	0,17	0,08	0,25
1130909	MG0400C040-040R01-MG	○	○	○	○	○	○	4,00	0,40	25,00	4,00	C	0,12	0,06	0,18
1130910	MG0400C040-040L01-MG	○	○	○	○	○	○	4,00	0,40	25,00	4,00	C	0,12	0,06	0,18

⊗ First choice | Primeira opção | 1ª opción    
 ⊗ Stock item | Produto de stock | Itens de stock    
 ○ Available under request | Disponível sobre consulta    
 ○ Stock available soon | Produto de stock disponível brevemente | Producto en stock disponible en breve    
 Insert order code = (1) Geometry Code + (2) Grade Code

⊗ Stock available soon | Produto de stock disponível brevemente | Producto en stock disponible en breve    
 2- Correspond to a Specific Holder

**MG...02-MG** Stable Grooving

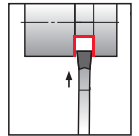
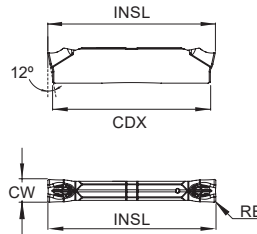

(1) Geometry code	(2) Grade code	M			S			Dimensions Dimensões Dimensiones (mm)					Cutting conditions Condições de corte Condiciones de corte			
		PVD			PVD			CW	RE	INSL	PSIRR/L	CDX	Seat <sup>2</sup> Size	fn (mm/r)	Min	Max
		6F	5C	3B	6F	5C	3B									
		PHL910	PHL920	PHL930	PHL910	PHL920	PHL930									
1130911	MG0200A015-N02-MG	⊗	⊗	⊗	⊗	⊗	⊗	2,00	0,15	22,00	-	20,00	A	0,07	0,03	0,10
1130842	MG0300B015-N02-MG	⊗	⊗	⊗	⊗	⊗	⊗	3,00	0,15	22,00	-	20,00	B	0,07	0,03	0,10
1130843	MG0300B030-N02-MG	⊗	⊗	⊗	⊗	⊗	⊗	3,00	0,30	22,00	-	20,00	B	0,15	0,08	0,22
1130912	MG0300B020-060R02-MG	⊗	⊗	⊗	⊗	⊗	⊗	3,00	0,20	22,00	6,00	20,00	B	0,11	0,05	0,16
1130913	MG0300B020-060L02-MG	⊗	⊗	⊗	⊗	⊗	⊗	3,00	0,20	22,00	6,00	20,00	B	0,11	0,05	0,16
1130914	MG0300B018-150R02-MG	○	○	○	○	○	○	3,00	0,18	22,00	15,00	20,00	B	0,08	0,04	0,12
1130915	MG0300B018-150L02-MG	○	○	○	○	○	○	3,00	0,18	22,00	15,00	20,00	B	0,08	0,04	0,12
1130868	MG0400C020-N02-MG	⊗	⊗	⊗	⊗	⊗	⊗	4,00	0,20	25,00	-	23,00	C	0,12	0,06	0,18
1130916	MG0400C040-N02-MG	○	○	○	○	○	○	4,00	0,40	25,00	-	23,00	C	0,17	0,08	0,25

⊗ First choice | Primeira opção | 1ª opción    
 ⊗ Stock item | Produto de stock | Itens de stock    
 ○ Available under request | Disponível sobre consulta    
 ○ Stock available soon | Produto de stock disponível brevemente | Producto en stock disponible en breve    
 Insert order code = (1) Geometry Code + (2) Grade Code

⊗ Stock available soon | Produto de stock disponível brevemente | Producto en stock disponible en breve    
 2- Correspond to a Specific Holder

**MG...02-PG** Profiling

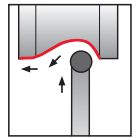
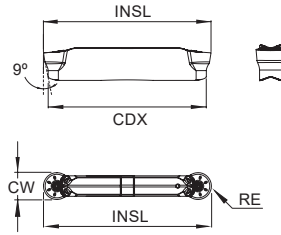

(1) Geometry code	(2) Grade code	P			K			Dimensions Dimensões Dimensiones (mm)					Cutting conditions Condições de corte Condiciones de corte					
		PVD			PVD			CW	RE	INSL	CDX	Seat <sup>2</sup> Size	AP (mm)	Min	Max	fn (mm/r)	Min	Max
		6F	5C	3B	6F	5C	3B											
1130917	MG0200A100-N02-PG	☉	☉		☉	☉		2,00	1,00	22,00	20,00	A	0,50	0,20	0,80	0,08	0,03	0,12
1130918	MG0300B150-N02-PG		○	○		○	○	3,00	1,50	22,00	20,00	B	1,00	0,40	1,60	0,10	0,05	0,15
1130848	MG0400C200-N02-PG		☉	☉		☉	☉	4,00	2,00	25,00	23,00	C	1,30	0,60	2,00	0,13	0,05	0,20
1130919	MG0500D250-N02-PG		○	○		○	○	5,00	2,50	25,00	23,00	D	1,50	0,70	2,20	0,13	0,06	0,20
1130920	MG0600E300-N02-PG		☉	☉		☉	☉	6,00	3,00	25,00	23,00	E	1,80	0,80	2,80	0,13	0,06	0,20

☉ First choice | Primeira opção | 1ª opción

☉ Stock item | Produto de stock | Itens de stock

○ Available under request | Disponível sobre consulta  
Disponível bajo consulta

Insert order code = (1) Geometry Code + (2) Grade Code

☉ Stock available soon | Produto de stock disponível brevemente | Producto en stock disponible en breve

2 - Correspond to a Specific Holder

**RECOMMENDED CUTTING CONDITIONS** Condições de corte recomendadas | Condiciones de corte recomendables

ISO	Material	HB (Brinell)	Vc (m/min)		
			← Wear Resistance		Toughness →
			PHL910	PHL920	PHL930
P	Unalloyed steel	125-170	100-265	90-260	75-250
	Low-alloy steel	180-350	80-240	70-230	65-220
	High-alloy steel	200-325	65-225	60-210	60-200
M	SS - Ferritic / Martensitic	200-330	90-165	80-160	70-150
	SS - Austenitic / Duplex	180-330	70-150	70-140	60-130
	SS - Ferritic / Duplex	230-260	55-140	50-130	50-120
K	Marble cast iron	130-230	110-225	105-220	100-210
	Grey cast iron	180-220	105-200	100-200	100-190
	Nodular cast iron	160-380	105-180	100-180	100-160
S	Heat resistant super alloys (Nickel base)	250-320	-	30-70	25-60
	Heat resistant super alloys (Cobalt base)	200-320	-	20-60	20-50
	Heat Resistant Super Alloys	200-320	-	25-65	25-45

# TOOLHOLDERS & MODULAR TOOLHOLDERS CODE KEY

Chave de codificação para suportes e suportes modulares | Llave de codificación de portaherramientas y portaherramientas modulares

For Toolholders

<b>MG</b>	<b>L</b>	<b>C</b>	-	<b>100</b>	<b>012</b>	<b>16.16</b>	<b>.A</b>	<b>.1</b>	-	<b>A</b>
<b>1</b>	<b>2</b>	<b>3</b>		<b>4</b>	<b>5</b>	<b>6</b>	<b>7</b>	<b>8</b>		<b>9</b>

For Modular Toolholders

<b>MG</b>	<b>L</b>	<b>C</b>	-	<b>100</b>	<b>16.16</b>	-	<b>A</b>
<b>1</b>	<b>2</b>	<b>3</b>		<b>4</b>	<b>6</b>		<b>9</b>

1 - Product Line

MG - Master Grooving

2 - Work Side

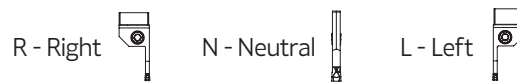

3 - Tool Type

C - Frontal    L - Lateral    MC - Modular Frontal    ML - Modular Lateral    M - Modular (for blades)

4 - Total toolholder length (mm)



5 - Maximum Depth of Cut (mm) (Suppressed on modular systems)

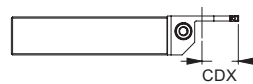

6 - Shaft | Cutting Unit Dimension

Example for 16.16 on the toolholder : B=16mm | H=16mm

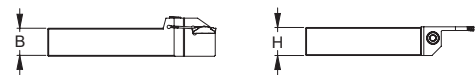

7 - Seat Size (Suppressed on modular systems)

A - 1,50mm | B - 2,50mm | C - 3,05mm | D - 4,00mm | E - 5,00mm

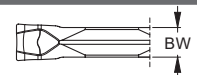

8 - Clamping System (Suppressed on modular systems)



9 - Coolant System (Suppressed if does not exist)

A - With coolant system

# PSC TOOLHOLDERS & MODULAR PSC TOOLHOLDERS CODE KEY



Chave de codificação para suportes PSC e suportes PSC modulares | Llave de codificación de portaherramientas PSC y portaherramientas PSC modulares

For PSC Toolholders

<b>PSC</b>	<b>32</b>	<b>-</b>	<b>MG</b>	<b>L</b>	<b>C</b>	<b>-</b>	<b>015</b>	<b>22</b>	<b>055</b>	<b>A</b>	<b>.1</b>	<b>-</b>	<b>A</b>
<b>1</b>	<b>2</b>		<b>3</b>	<b>4</b>	<b>5</b>		<b>6</b>	<b>7</b>	<b>8</b>	<b>9</b>	<b>10</b>		<b>11</b>

For Modular PSC Toolholders

<b>PSC</b>	<b>32</b>	<b>-</b>	<b>MG</b>	<b>L</b>	<b>ML</b>	<b>18</b>	<b>040</b>	<b>-</b>	<b>A</b>
<b>1</b>	<b>2</b>		<b>3</b>	<b>4</b>	<b>5</b>	<b>7</b>	<b>8</b>		<b>11</b>

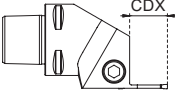
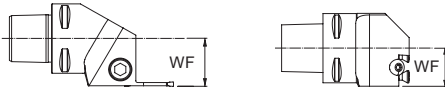
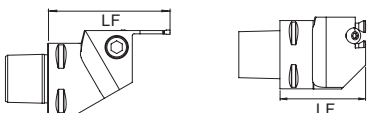
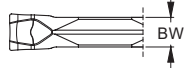
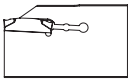
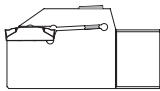
1 - Modular System	2 - Size			
PSC - Polygonal Shank Coupling	32   40   50   63			
3 - Product Line				
MG - Master Grooving				
4 - Work Side				
R - Right 	N - Neutral 	L - Left 		
5 - Tool Type				
C - Frontal	L - Lateral	MC - Modular Frontal	ML - Modular Lateral	M - Modular (for blades)
6 - Maximum Depth of Cut (mm)				
				
7 - Functional width (mm)				
				
8 - Functional length (mm)				
				
9 - Seat Size (Suppressed on modular systems)				
A - 1,50mm   B - 2,50mm   C - 3,05mm   D - 4,00mm   E - 5,00mm				
				
10 - Clamping System (Suppressed on modular systems)				
0 - Spring 	1 - Screw 			
11 - Coolant System (Suppressed if does not exist)				
A - With coolant system				

# BLADES & MODULAR CARTRIDGES CODE KEY

Chave de codificação para lâminas e cartuchos modulares | Llave de codificación de lamas y cartuchos modulares

For Blades

<b>MG</b>	<b>N</b>	<b>C</b>	<b>-</b>	<b>020</b>	<b>21</b>	<b>.A</b>	<b>.0</b>	<b>-</b>	<b>A</b>
<b>1</b>	<b>2</b>	<b>3</b>		<b>4</b>	<b>5</b>	<b>7</b>	<b>8</b>		<b>9</b>

For Modular Cartridges

<b>MG</b>	<b>L</b>	<b>M</b>	<b>-</b>	<b>012</b>	<b>040-055</b>	<b>.A</b>	<b>.1</b>	<b>-</b>	<b>A</b>
<b>1</b>	<b>2</b>	<b>3</b>		<b>4</b>	<b>6</b>	<b>7</b>	<b>8</b>		<b>9</b>

1 - Product Line

MG - Master Grooving

2 - Work Side

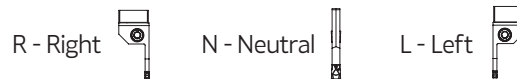

4 - Tool Type

C - Frontal

L - Lateral

MC - Modular Frontal

ML - Modular Lateral

M - Modular (for blades)

5 - Cutting Unit Dimension (for blades)

**21** : HF=21mm

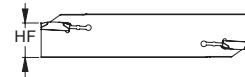

6 - Diameter range (for face grooving cartridges)

**040-055** : 44 mm to 55mm

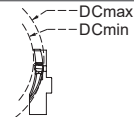

7 - Seat Size

A - 1,50mm | B - 2,50mm | C - 3,05mm | D - 4,00mm | E - 5,00mm

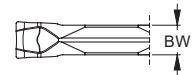

8 - Clamping System

0 - Spring

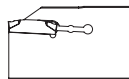

1 - Screw

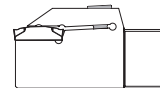

9 - Coolant System (Suppressed if does not exist)

A - With coolant system

**MGNC**

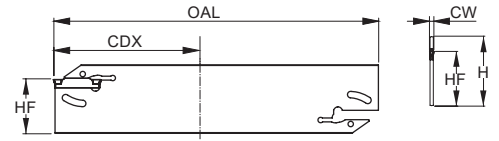

Order code Código	Reference Referência Referencia	Dimensions   Dimensões   Dimensiones (mm)					WT	Seat Size	Insert	Number of inserts	Toolholder		Wrench	Stock
		CDX	OAL	H	HF	CW					CPTS	DPTS		
183043900	MGNC-038 21.A.0	38	110	26	21,4	2	0,060	A	MG.. 02	1	CPTS 26... DPTS 26...	290079600	☉	
183044100	MGNC-062 25.A.0	62	150	32	25,0	2	0,090	A	MG.. 02	2	CPTS 32... DPTS 32...	290079600	☉	
183044000	MGNC-038 21.B.0	38	110	26	21,4	3	0,070	B	MG.. 03	1	CPTS 26... DPTS 26...	290079600	☉	
183044200	MGNC-062 25.B.0	62	150	32	25,0	3	0,100	B	MG.. 03	2	CPTS 32... DPTS 32...	290079600	☉	
183044300	MGNC-062 25.C.0	62	150	32	25,0	4	0,125	C	MG.. 04	2	CPTS 32... DPTS 32...	290079600	☉	

☉ Stock item | Produto de stock | Itens de stock

○ Available under request | Disponível sobre consulta | Disponible bajo consulta

Note: For inserts with 2 cutting edges, the CDX is defined by the insert

**CPTS**

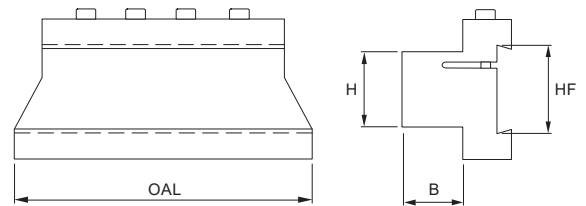

Order code Código	Reference Referência Referencia	Dimensions   Dimensões   Dimensiones (mm)				WT	Screw	Wrench	Stock
		HF	OAL	H	B				
290008200	CPTS 2616	26	76	16	16	0,450	290020700	290021300	☉
290006000	CPTS 2620	26	87	20	20	0,500	290020700	290021300	☉
290006100	CPTS 2625	26	87	25	25	0,650	290020700	290021300	☉
290006200	CPTS 3220	32	100	20	20	0,700	290020700	290021300	☉
290005000	CPTS 3225	32	110	25	25	0,950	290020700	290021300	☉
290006300	CPTS 3232	32	120	32	32	1,400	290020700	290021300	☉

☉ Stock item | Produto de stock | Itens de stock

○ Available under request | Disponível sobre consulta | Disponible bajo consulta

**DPTS**

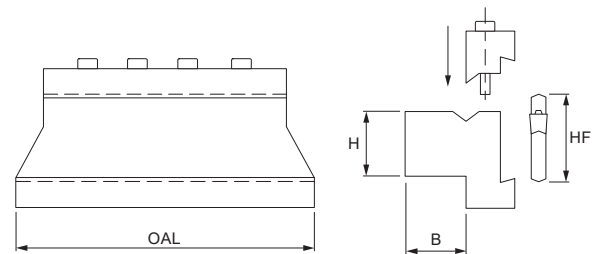

Order code Código	Reference Referência Referencia	Dimensions   Dimensões   Dimensiones (mm)				WT	Screw	Wrench	Stock
		HF	OAL	H	B				
290045500	DPTS 2620	26	87	20	20	0,550	290020700	290021300	☉
290046600	DPTS 2625	26	87	25	25	0,700	290020700	290021300	☉
290073600	DPTS 3220	32	100	20	20	0,750	290020700	290021300	☉
290073700	DPTS 3225	32	110	25	25	1,000	290020700	290021300	☉
290073800	DPTS 3232	32	120	32	32	1,450	290020700	290021300	☉

☉ Stock item | Produto de stock | Itens de stock

○ Available under request | Disponível sobre consulta | Disponible bajo consulta

**MGLC**

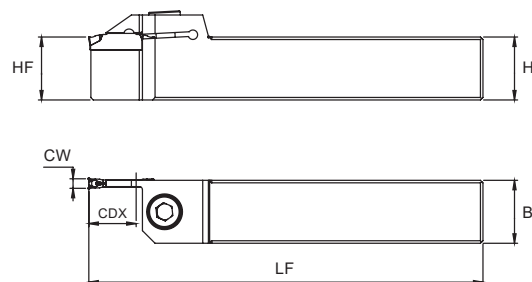

Order code Código	Reference Referência Referencia	Dimensions   Dimensões   Dimensiones (mm)						WT	Seat Size	Insert	Screw	Wrench	Nm	Stock
		CDX	LF	B	H	HF	CW							
183041100	MGLC-100 012 16.16.A.1	12	100	16	16	16	2	0,180	A	MG .. 02	290098600	290021300	2,0	☺
183041700	MGLC-125 012 20.20.A.1	12	125	20	20	20	2	0,370	A	MG .. 02	290087400	290021300	2,0	☺
183041300	MGLC-100 012 16.16.B.1	12	100	16	16	16	3	0,180	B	MG .. 03	290098600	290021300	2,0	☺
183041500	MGLC-100 020 16.16.B.1	20	100	16	16	16	3	0,170	B	MG .. 03	290098600	290021300	2,0	○
183041900	MGLC-125 012 20.20.B.1	12	125	20	20	20	3	0,370	B	MG .. 03	290087400	290021300	2,0	○
183042100	MGLC-125 020 20.20.B.1	20	125	20	20	20	3	0,350	B	MG .. 03	290087400	290021300	2,0	☺
183042600	MGLC-150 012 25.25.B.1	12	150	25	25	25	3	0,680	B	MG .. 03	290087400	290021300	2,0	☺
183042800	MGLC-150 020 25.25.B.1	20	150	25	25	25	3	0,650	B	MG .. 03	290087400	290021300	2,0	☺
183042200	MGLC-125 012 20.20.C.1	12	125	20	20	20	4	0,370	C	MG .. 04	290087400	290021300	3,0	○
183042400	MGLC-125 020 20.20.C.1	20	125	20	20	20	4	0,350	C	MG .. 04	290087400	290021300	3,0	○
183042900	MGLC-150 012 25.25.C.1	12	150	25	25	25	4	0,680	C	MG .. 04	290087400	290021300	3,0	☺
183043100	MGLC-150 020 25.25.C.1	20	150	25	25	25	4	0,650	C	MG .. 04	290087400	290021300	3,0	☺
183043300	MGLC-150 012 25.25.D.1	12	150	25	25	25	5	0,680	D	MG .. 05	290087400	290021300	3,0	☺
183043500	MGLC-150 022 25.25.D.1	22	150	25	25	25	5	0,650	D	MG .. 05	290087400	290021300	3,0	☺
183043700	MGLC-150 022 25.25.E.1	22	150	25	25	25	6	0,650	E	MG .. 06	290087400	290021300	4,0	○

☺ Stock item | Produto de stock | Itens de stock      ○ Available under request | Disponível sobre consulta | Disponible bajo consulta

**MGRC**

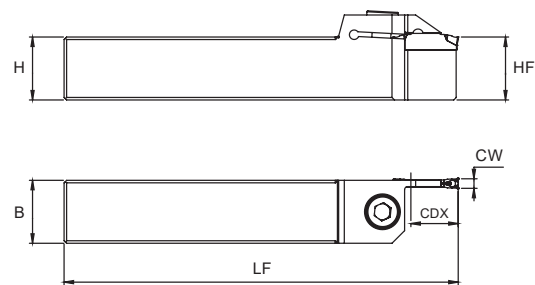

Order code Código	Reference Referência Referencia	Dimensions   Dimensões   Dimensiones (mm)						WT	Seat Size	Insert	Screw	Wrench	Nm	Stock
		CDX	LF	B	H	HF	CW							
183041200	MGRC-100 012 16.16.A.1	12	100	16	16	16	2	0,180	A	MG .. 02	290098600	290021300	2,0	☺
183041800	MGRC-125 012 20.20.A.1	12	125	20	20	20	2	0,370	A	MG .. 02	290087400	290021300	2,0	☺
183041400	MGRC-100 012 16.16.B.1	12	100	16	16	16	3	0,180	B	MG .. 03	290098600	290021300	2,0	☺
183041600	MGRC-100 020 16.16.B.1	20	100	16	16	16	3	0,170	B	MG .. 03	290098600	290021300	2,0	☺
183042000	MGRC-125 012 20.20.B.1	12	125	20	20	20	3	0,370	B	MG .. 03	290087400	290021300	2,0	☺
183040800	MGRC-125 020 20.20.B.1	20	125	20	20	20	3	0,350	B	MG .. 03	290087400	290021300	2,0	☺
183042700	MGRC-150 012 25.25.B.1	12	150	25	25	25	3	0,680	B	MG .. 03	290087400	290021300	2,0	☺
183040900	MGRC-150 020 25.25.B.1	20	150	25	25	25	3	0,650	B	MG .. 03	290087400	290021300	2,0	☺
183042300	MGRC-125 012 20.20.C.1	12	125	20	20	20	4	0,370	C	MG .. 04	290087400	290021300	3,0	☺
183042500	MGRC-125 020 20.20.C.1	20	125	20	20	20	4	0,350	C	MG .. 04	290087400	290021300	3,0	☺
183043000	MGRC-150 012 25.25.C.1	12	150	25	25	25	4	0,680	C	MG .. 04	290087400	290021300	3,0	☺
183043200	MGRC-150 020 25.25.C.1	20	150	25	25	25	4	0,650	C	MG .. 04	290087400	290021300	3,0	☺
183043400	MGRC-150 012 25.25.D.1	12	150	25	25	25	5	0,680	D	MG .. 05	290087400	290021300	3,0	☺
183043600	MGRC-150 022 25.25.D.1	22	150	25	25	25	5	0,650	D	MG .. 05	290087400	290021300	3,0	☺
183043800	MGRC-150 022 25.25.E.1	22	150	25	25	25	6	0,650	E	MG .. 06	290087400	290021300	4,0	☺

☺ Stock item | Produto de stock | Itens de stock      ○ Available under request | Disponível sobre consulta | Disponible bajo consulta

**PSC L**

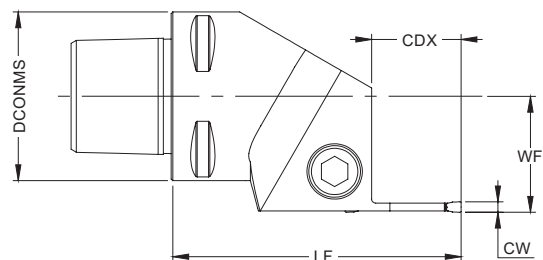
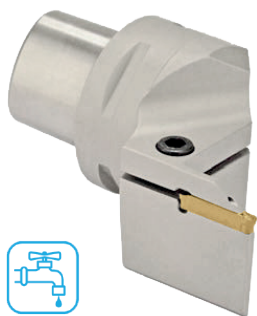

Order code Código	Reference Referência Referencia	Dimensions   Dimensões   Dimensiones (mm)					WT	Seat Size	Insert	Screw	Wrench	Nm	Stock
		DCONMS	WF	LF	CDX	CW							
183052000	PSC32-MGLC 015 22055 A.1-A	32	22	55	15	2	0,250	A	MG.. 02	290062800	290021300	2,0	○
183052200	PSC40-MGLC 015 27055 A.1-A	40	27	55	15	2	0,430	A	MG.. 02	290087500	290021300	2,0	○
183052400	PSC50-MGLC 015 35060 A.1-A	50	35	60	15	2	0,800	A	MG.. 02	290087500	290021300	2,0	○
183052600	PSC32-MGLC 020 22055 B.1-A	32	22	55	20	3	0,250	B	MG.. 03	290062800	290021300	2,0	○
183052800	PSC40-MGLC 020 27060 B.1-A	40	27	60	20	3	0,480	B	MG.. 03	290087500	290021300	2,0	○
183053000	PSC50-MGLC 020 35060 B.1-A	50	35	60	20	3	0,800	B	MG.. 03	290087500	290021300	2,0	○
183053200	PSC63-MGLC 020 45065 B.1-A	63	45	65	20	3	1,100	B	MG.. 03	290087500	290021300	2,0	○
183053400	PSC32-MGLC 020 22060 C.1-A	32	22	60	20	4	0,260	C	MG.. 04	290062800	290021300	3,0	○
183053600	PSC40-MGLC 025 27067 C.1-A	40	27	67	25	4	0,440	C	MG.. 04	290087500	290021300	3,0	○
183053800	PSC50-MGLC 025 35067 C.1-A	50	35	67	25	4	0,800	C	MG.. 04	290087500	290021300	3,0	○
183054000	PSC63-MGLC 025 45070 C.1-A	63	45	70	25	4	1,350	C	MG.. 04	290087500	290021300	3,0	○
183054200	PSC40-MGLC 025 27067 D.1-A	40	27	67	25	5	0,440	D	MG.. 05	290087500	290021300	3,0	○
183054400	PSC50-MGLC 025 35067 D.1-A	50	35	67	25	5	0,800	D	MG.. 05	290087500	290021300	3,0	○
183054600	PSC63-MGLC 025 45070 D.1-A	63	45	70	25	5	1,350	D	MG.. 05	290087500	290021300	3,0	○
183054800	PSC40-MGLC 025 27070 E.1-A	40	27	70	25	6	0,440	E	MG.. 06	290087500	290021300	4,0	○
183055000	PSC50-MGLC 025 35070 E.1-A	50	35	70	25	6	0,780	E	MG.. 06	290087500	290021300	4,0	○
183055200	PSC63-MGLC 025 45075 E.1-A	63	45	75	25	6	1,430	E	MG.. 06	290087500	290021300	4,0	○

⊗ Stock item | Produto de stock | Itens de stock      ○ Available under request | Disponível sobre consulta | Disponible bajo consulta

**PSC R**

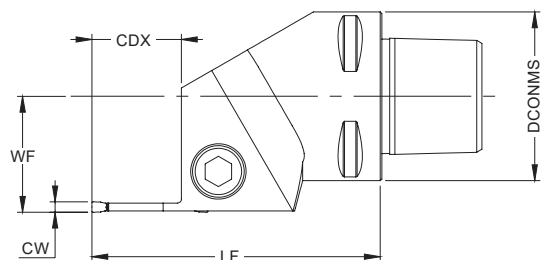
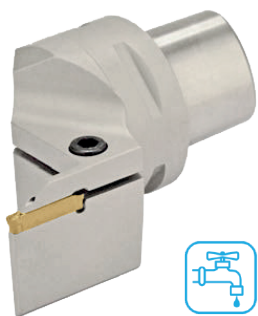

Order code Código	Reference Referência Referencia	Dimensions   Dimensões   Dimensiones (mm)					WT	Seat Size	Insert	Screw	Wrench	Nm	Stock
		DCONMS	WF	LF	CDX	CW							
183052100	PSC32-MGRC 015 22055 A.1-A	32	22	55	15	2	0,250	A	MG.. 02	290062800	290021300	2,0	○
183052300	PSC40-MGRC 015 27055 A.1-A	40	27	55	15	2	0,430	A	MG.. 02	290087500	290021300	2,0	○
183052500	PSC50-MGRC 015 35060 A.1-A	50	35	60	15	2	0,800	A	MG.. 02	290087500	290021300	2,0	○
183052700	PSC32-MGRC 020 22055 B.1-A	32	22	55	20	3	0,250	B	MG.. 03	290062800	290021300	2,0	○
183052900	PSC40-MGRC 020 27060 B.1-A	40	27	60	20	3	0,480	B	MG.. 03	290087500	290021300	2,0	○
183053100	PSC50-MGRC 020 35060 B.1-A	50	35	60	20	3	0,800	B	MG.. 03	290087500	290021300	2,0	○
183053300	PSC63-MGRC 020 45065 B.1-A	63	45	65	20	3	1,100	B	MG.. 03	290087500	290021300	2,0	○
183053500	PSC32-MGRC 020 22060 C.1-A	32	22	60	20	4	0,260	C	MG.. 04	290062800	290021300	3,0	○
183053700	PSC40-MGRC 025 27067 C.1-A	40	27	67	25	4	0,440	C	MG.. 04	290087500	290021300	3,0	○
183053900	PSC50-MGRC 025 35067 C.1-A	50	35	67	25	4	0,800	C	MG.. 04	290087500	290021300	3,0	○
183054100	PSC63-MGRC 025 45070 C.1-A	63	45	70	25	4	1,350	C	MG.. 04	290087500	290021300	3,0	○
183054300	PSC40-MGRC 025 27067 D.1-A	40	27	67	25	5	0,440	D	MG.. 05	290087500	290021300	3,0	○
183054500	PSC50-MGRC 025 35067 D.1-A	50	35	67	25	5	0,800	D	MG.. 05	290087500	290021300	3,0	○
183054700	PSC63-MGRC 025 45070 D.1-A	63	45	70	25	5	1,350	D	MG.. 05	290087500	290021300	3,0	○
183054900	PSC40-MGRC 025 27070 E.1-A	40	27	70	25	6	0,440	E	MG.. 06	290087500	290021300	4,0	○
183055100	PSC50-MGRC 025 35070 E.1-A	50	35	70	25	6	0,780	E	MG.. 06	290087500	290021300	4,0	○
183055300	PSC63-MGRC 025 45075 E.1-A	63	45	75	25	6	1,430	E	MG.. 06	290087500	290021300	4,0	○

⊗ Stock item | Produto de stock | Itens de stock      ○ Available under request | Disponível sobre consulta | Disponible bajo consulta

## MGLMC

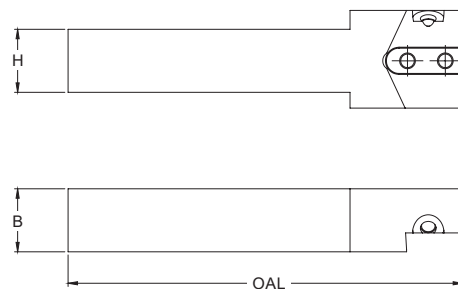
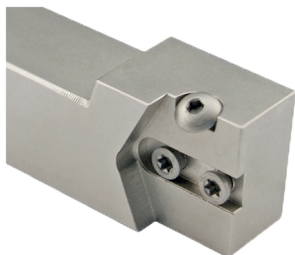

Order code Código	Reference Referência Referencia	Dimensions   Dimensões Dimensiones (mm)				WT	Cartridge	Allen Screw	Allen Wrench	Nm	Torx Screw	Torx Wrench	Nm	Stock
		H	B	OAL	CW									
183044400	MGLMC-125 20.20	20	20	125	2-6	0,310	MGLM	290029900	290038400	7,0	290078500	290013200	3,0	☉
183044600	MGLMC-150 25.25	25	25	150	2-6	0,610	MGLM	290029900	290038400	7,0	290029900	290013200	3,0	☉
183044800	MGLMC-170 32.32	32	32	170	2-6	1,300	MGLM	290029900	290038400	7,0	290029900	290013200	3,0	☉

☉ Stock item | Produto de stock | Itens de stock

○ Available under request | Disponível sobre consulta | Disponible bajo consulta

## MGRMC

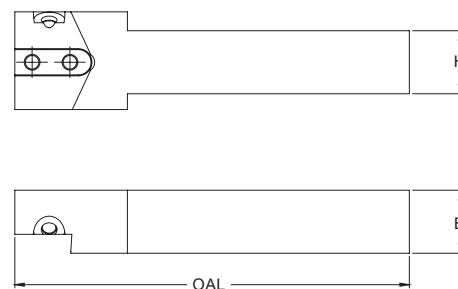
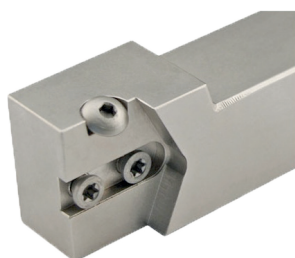

Order code Código	Reference Referência Referencia	Dimensions   Dimensões Dimensiones (mm)				WT	Cartridge	Allen Screw	Allen Wrench	Nm	Torx Screw	Torx Wrench	Nm	Stock
		H	B	OAL	CW									
183044500	MGRMC-125 20.20	20	20	125	2-6	0,310	MGRM	290029900	290038400	7,0	290029900	290013200	3,0	☉
183044700	MGRMC-150 25.25	25	25	150	2-6	0,610	MGRM	290029900	290038400	7,0	290029900	290013200	3,0	☉
183044900	MGRMC-170 32.32	32	32	170	2-6	1,300	MGRM	290029900	290038400	7,0	290029900	290013200	3,0	☉

☉ Stock item | Produto de stock | Itens de stock

○ Available under request | Disponível sobre consulta | Disponible bajo consulta

## MGLML

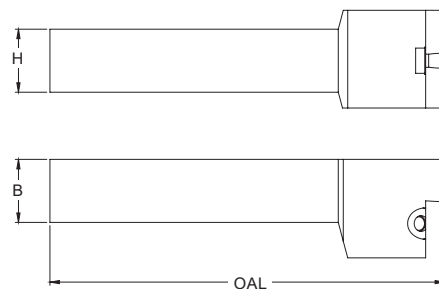
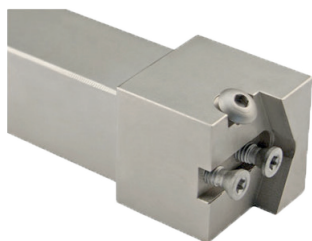

Order code Código	Reference Referência Referencia	Dimensions   Dimensões Dimensiones (mm)				WT	Cartridge	Allen Screw	Allen Wrench	Nm	Torx Screw	Torx Wrench	Nm	Stock
		H	B	OAL	CW									
183045000	MGLML-125 20.20	20	20	125	2-6	0,450	MGRM	290029900	290038400	7,0	290029900	290013200	3,0	📦
183045200	MGLML-150 25.25	25	25	150	2-6	0,780	MGRM	290029900	290038400	7,0	290029900	290013200	3,0	📦
183045400	MGLML-170 32.32	32	32	170	2-6	1,400	MGRM	290029900	290038400	7,0	290029900	290013200	3,0	📦

📦 Stock item | Produto de stock | Itens de stock

○ Available under request | Disponível sobre consulta | Disponible bajo consulta

## MGRML

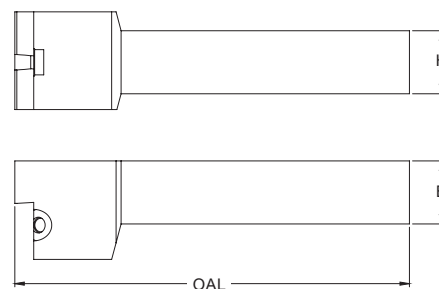
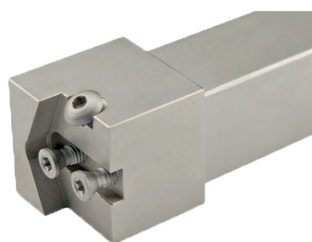

Order code Código	Reference Referência Referencia	Dimensions   Dimensões Dimensiones (mm)				WT	Cartridge	Allen Screw	Allen Wrench	Nm	Torx Screw	Torx Wrench	Nm	Stock
		H	B	OAL	CW									
183045100	MGRML-125 20.20	20	20	125	2-6	0,450	MGLM	290029900	290038400	7,0	290029900	290013200	3,0	📦
183045300	MGRML-150 25.25	25	25	150	2-6	0,780	MGLM	290029900	290038400	7,0	290029900	290013200	3,0	📦
183045500	MGRML-170 32.32	32	32	170	2-6	1,400	MGLM	290029900	290038400	7,0	290029900	290013200	3,0	📦

📦 Stock item | Produto de stock | Itens de stock

○ Available under request | Disponível sobre consulta | Disponible bajo consulta

## PSC-MGLMC

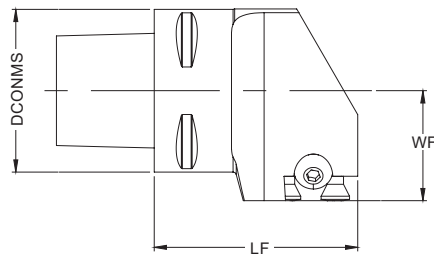

Order code Código	Reference Referência Referencia	Dimensions   Dimensões Dimensiones (mm)				WT	Cartridge	Allen Screw	Allen Wrench	Nm	Torx Screw	Torx Wrench	Nm	Stock
		DCONMS	WF	LF	CW									
183056200	PSC32-MGLMC 22042	32	22	42	2-6	0,280	MGLM	290029900	290038400	7,00	290078500	290013200	2,0	○
183056400	PSC40-MGLMC 27050	40	27	50	2-6	0,490	MGLM	290029900	290038400	7,00	290078500	290013200	2,0	○
183056600	PSC50-MGLMC 30050	50	30	50	2-6	0,740	MGLM	290029900	290038400	7,00	290078500	290013200	2,0	○
183056800	PSC63-MGLMC 45055	63	45	55	2-6	1,240	MGLM	290029900	290038400	7,00	290078500	290013200	2,0	○

Stock item | Produto de stock | Itens de stock

○ Available under request | Disponível sobre consulta | Disponible bajo consulta

## PSC-MGRMC

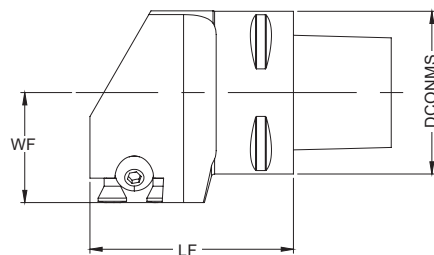

Order code Código	Reference Referência Referencia	Dimensions   Dimensões Dimensiones (mm)				WT	Cartridge	Allen Screw	Allen Wrench	Nm	Torx Screw	Torx Wrench	Nm	Stock
		DCONMS	WF	LF	CW									
183056300	PSC32-MGRMC 22042	32	22	42	2-6	0,280	MGRM	290029900	290038400	7,00	290078500	290013200	2,0	○
183056500	PSC40-MGRMC 27050	40	27	50	2-6	0,490	MGRM	290029900	290038400	7,00	290078500	290013200	2,0	○
183056700	PSC50-MGRMC 30050	50	30	50	2-6	0,740	MGRM	290029900	290038400	7,00	290078500	290013200	2,0	○
183056900	PSC63-MGRMC 45055	63	45	55	2-6	1,240	MGRM	290029900	290038400	7,00	290078500	290013200	2,0	○

Stock item | Produto de stock | Itens de stock

○ Available under request | Disponível sobre consulta | Disponible bajo consulta

## PSC-MGLML

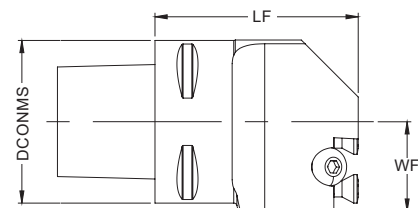

Order code Código	Reference Referência Referencia	Dimensions   Dimensões Dimensiones (mm)				WT	Cartridge	Allen Screw	Allen Wrench	Nm	Torx Screw	Torx Wrench	Nm	Stock
		DCONMS	WF	LF	CW									
183055400	PSC32-MGLML 18040	32	18	40	2-6	0,250	MGRM	290029900	290038400	7,00	290078500	290013200	2,0	○
183055600	PSC40-MGLML 22050	40	22	50	2-6	0,470	MGRM	290029900	290038400	7,00	290078500	290013200	2,0	○
183055800	PSC50-MGLML 27060	50	27	60	2-6	0,860	MGRM	290029900	290038400	7,00	290078500	290013200	2,0	○
183056000	PSC63-MGLML 34065	63	34	65	2-6	1,440	MGRM	290029900	290038400	7,00	290078500	290013200	2,0	○

☒ Stock item | Produto de stock | Itens de stock

○ Available under request | Disponível sobre consulta | Disponible bajo consulta

## PSC-MGRML

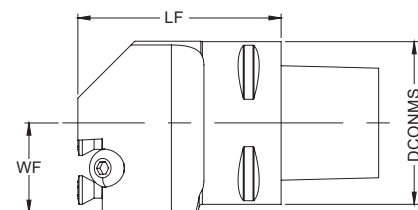

Order code Código	Reference Referência Referencia	Dimensions   Dimensões Dimensiones (mm)				WT	Cartridge	Allen Screw	Allen Wrench	Nm	Torx Screw	Torx Wrench	Nm	Stock
		DCONMS	WF	LF	CW									
183055500	PSC32-MGRML 18040	32	18	40	2-6	0,250	MGLM	290029900	290038400	7,00	290078500	290013200	2,0	○
183055700	PSC40-MGRML 22050	40	22	50	2-6	0,470	MGLM	290029900	290038400	7,00	290078500	290013200	2,0	○
183055900	PSC50-MGRML 27060	50	27	60	2-6	0,860	MGLM	290029900	290038400	7,00	290078500	290013200	2,0	○
183056100	PSC63-MGRML 34065	63	34	65	2-6	1,440	MGLM	290029900	290038400	7,00	290078500	290013200	2,0	○

☒ Stock item | Produto de stock | Itens de stock

○ Available under request | Disponível sobre consulta | Disponible bajo consulta

## MGLM

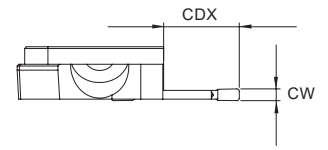
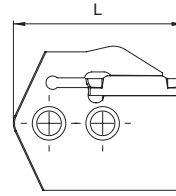

Order code Código	Reference Referência Referencia	Dimensions   Dimensões   Dimensiones (mm)			WT	Seat Size	Insert	Stock
		CDX	L	CW				
183045600	MGLM 012 A.1	12	38	2	0,040	A	MG.. 02	⊗
183045800	MGLM 020 A.1	20	46	2	0,040	A	MG.. 02	○
183046000	MGLM 012 B.1	12	38	3	0,040	B	MG.. 03	○
183046200	MGLM 020 B.1	20	46	3	0,040	B	MG.. 03	○
183046400	MGLM 012 C.1	12	38	4	0,040	C	MG.. 04	⊗
183046600	MGLM 020 C.1	20	46	4	0,040	C	MG.. 04	⊗
183046800	MGLM 012 D.1	12	38	5	0,040	D	MG.. 05	○
183047000	MGLM 022 D.1	22	48	5	0,040	D	MG.. 05	○
183047200	MGLM 012 E.1	12	38	6	0,040	E	MG.. 06	○
183047400	MGLM 022 E.1	22	48	6	0,040	E	MG.. 06	○

⊗ Stock item | Produto de stock | Itens de stock      ○ Available under request | Disponível sobre consulta | Disponible bajo consulta

## MGRM

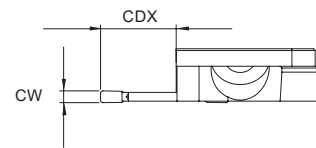
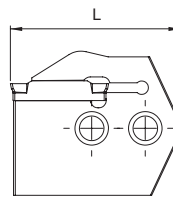

Order code Código	Reference Referência Referencia	Dimensions   Dimensões   Dimensiones (mm)			WT	Seat Size	Insert	Stock
		CDX	L	CW				
183045700	MGRM 012 A.1	12	38	2	0,040	A	MG.. 02	⊗
183045900	MGRM 020 A.1	20	46	2	0,040	A	MG.. 02	⊗
183046100	MGRM 012 B.1	12	38	3	0,040	B	MG.. 03	○
183046300	MGRM 020 B.1	20	46	3	0,040	B	MG.. 03	○
183046500	MGRM 012 C.1	12	38	4	0,040	C	MG.. 04	⊗
183046700	MGRM 020 C.1	20	46	4	0,040	C	MG.. 04	⊗
183046900	MGRM 012 D.1	12	38	5	0,040	D	MG.. 05	○
183047100	MGRM 022 D.1	22	48	5	0,040	D	MG.. 05	○
183047300	MGRM 012 E.1	12	38	6	0,040	E	MG.. 06	○
183047500	MGRM 022 E.1	22	48	6	0,040	E	MG.. 06	○

⊗ Stock item | Produto de stock | Itens de stock

○ Available under request | Disponível sobre consulta | Disponible bajo consulta

## MGLM Face Grooving

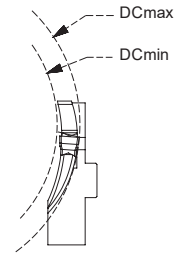
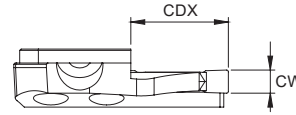
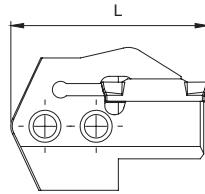

Order code Código	Reference Referência Referencia	Dimensions   Dimensões   Dimensiones (mm)			WT	Seat Size	Diameter Range (mm)	Insert	Stock
		CDX	L	CW					
183047600	MGLM 012 040-055 B.1	12	38	3	0,040	B	40-55	MG.. 03	○
183047800	MGLM 015 055-070 B.1	15	41	3	0,040	B	55-70	MG.. 03	○
183048000	MGLM 018 070-098 B.1	18	44	3	0,040	B	70-98	MG.. 03	○
183048200	MGLM 018 090-140 B.1	18	44	3	0,040	B	90-140	MG.. 03	⊗
183048400	MGLM 018 130-300 B.1	18	44	3	0,040	B	130-300	MG.. 03	○
183048600	MGLM 018 300-999 B.1	18	44	3	0,040	B	300-999	MG.. 03	○
183048800	MGLM 018 040-055 C.1	18	44	4	0,040	C	40-55	MG.. 04	○
183049000	MGLM 018 055-070 C.1	18	44	4	0,040	C	55-70	MG.. 04	⊗
183049200	MGLM 018 070-098 C.1	18	44	4	0,040	C	70-98	MG.. 04	○
183049400	MGLM 018 090-140 C.1	18	44	4	0,040	C	90-140	MG.. 04	○
183049600	MGLM 018 130-300 C.1	18	44	4	0,040	C	130-300	MG.. 04	○
183049800	MGLM 018 300-999 C.1	18	44	4	0,040	C	300-999	MG.. 04	○
183050000	MGLM 020 050-070 D.1	20	46	5	0,040	D	50-70	MG.. 05	○
183050200	MGLM 020 070-098 D.1	20	46	5	0,040	D	70-98	MG.. 05	○
183050400	MGLM 020 090-140 D.1	20	46	5	0,040	D	90-140	MG.. 05	○
183050600	MGLM 020 130-300 D.1	20	46	5	0,040	D	130-300	MG.. 05	○
183050800	MGLM 020 300-999 D.1	20	46	5	0,040	D	300-999	MG.. 05	○
183051000	MGLM 020 050-070 E.1	20	46	6	0,040	E	50-70	MG.. 06	○
183051200	MGLM 020 070-098 E.1	20	46	6	0,040	E	70-98	MG.. 06	○
183051400	MGLM 020 090-140 E.1	20	46	6	0,040	E	90-140	MG.. 06	⊗
183051600	MGLM 020 130-300 E.1	20	46	6	0,040	E	130-300	MG.. 06	○
183051800	MGLM 020 300-999 E.1	20	46	6	0,040	E	300-999	MG.. 06	○

⊗ Stock item | Produto de stock | Itens de stock      ○ Available under request | Disponível sobre consulta | Disponible bajo consulta

## MGRM Face Grooving

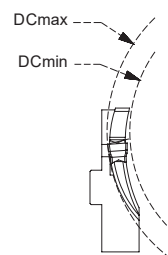
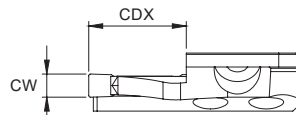
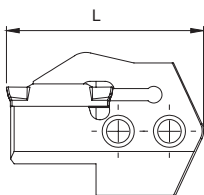

Order code Código	Reference Referência Referencia	Dimensions   Dimensões   Dimensiones (mm)			WT	Seat Size	Diameter Range (mm)	Insert	Stock
		CDX	L	CW					
183047700	MGRM 012 040-055 B.1	12	38	3	0,040	B	40-55	MG.. 03	○
183047900	MGRM 015 055-070 B.1	15	41	3	0,040	B	55-70	MG.. 03	○
183048100	MGRM 018 070-098 B.1	18	44	3	0,040	B	70-98	MG.. 03	○
183048300	MGRM 018 090-140 B.1	18	44	3	0,040	B	90-140	MG.. 03	○
183048500	MGRM 018 130-300 B.1	18	44	3	0,040	B	130-300	MG.. 03	○
183048700	MGRM 018 300-999 B.1	18	44	3	0,040	B	300-999	MG.. 03	○
183048900	MGRM 018 040-055 C.1	18	44	4	0,040	C	40-55	MG.. 04	○
183049100	MGRM 018 055-070 C.1	18	44	4	0,040	C	55-70	MG.. 04	○
183049300	MGRM 018 070-098 C.1	18	44	4	0,040	C	70-98	MG.. 04	○
183049500	MGRM 018 090-140 C.1	18	44	4	0,040	C	90-140	MG.. 04	○
183049700	MGRM 018 130-300 C.1	18	44	4	0,040	C	130-300	MG.. 04	○
183049900	MGRM 018 300-999 C.1	18	44	4	0,040	C	300-999	MG.. 04	○
183050100	MGRM 020 050-070 D.1	20	46	5	0,040	D	50-70	MG.. 05	○
183050300	MGRM 020 070-098 D.1	20	46	5	0,040	D	70-98	MG.. 05	○
183050500	MGRM 020 090-140 D.1	20	46	5	0,040	D	90-140	MG.. 05	○
183050700	MGRM 020 130-300 D.1	20	46	5	0,040	D	130-300	MG.. 05	○
183050900	MGRM 020 300-999 D.1	20	46	5	0,040	D	300-999	MG.. 05	○
183051100	MGRM 020 050-070 E.1	20	46	6	0,040	E	50-70	MG.. 06	○
183051300	MGRM 020 070-098 E.1	20	46	6	0,040	E	70-98	MG.. 06	○
183051500	MGRM 020 090-140 E.1	20	46	6	0,040	E	90-140	MG.. 06	○
183051700	MGRM 020 130-300 E.1	20	46	6	0,040	E	130-300	MG.. 06	○
183051900	MGRM 020 300-999 E.1	20	46	6	0,040	E	300-999	MG.. 06	○

Stock item | Produto de stock | Itens de stock

○ Available under request | Disponível sobre consulta | Disponible bajo consulta

## ROUGHING - GROOVE TURNING

### Use multiple passes:

Combine plunge and side-feed steps to open the groove gradually.

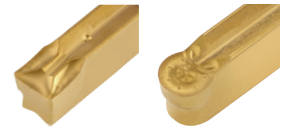

-UG

-PG

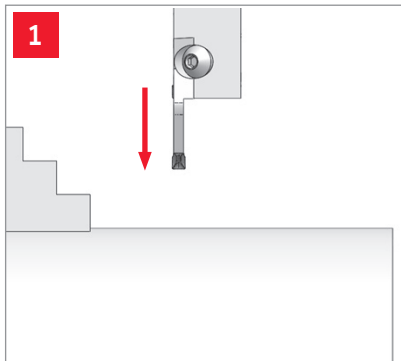

**1.** Initiate radial entry from the side nearest to the spindle.

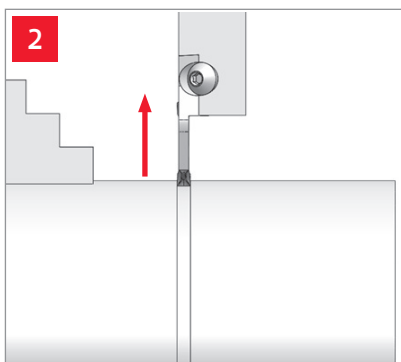

**2.** Retract the tool radially by 0,10 mm to unload the cutting edge and manage chip breaking.

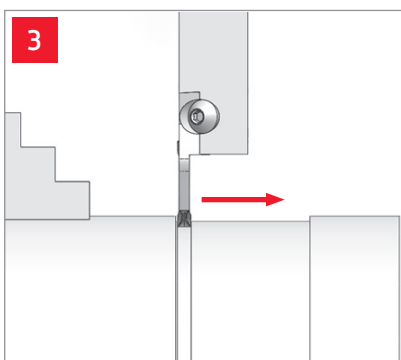

**3.** Feed axially along the part.

## ROUGHING - GROOVE TURNING

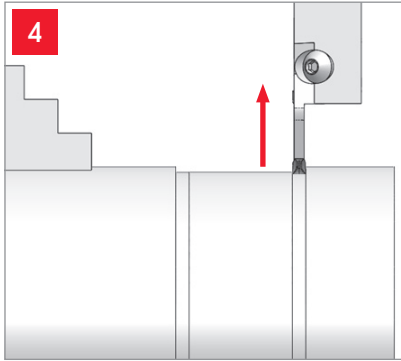
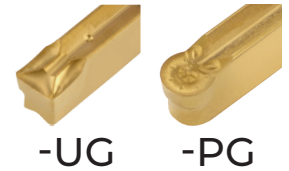

**4.** Retract radially again (~ 0,10 mm) after the turning pass to relieve the insert.

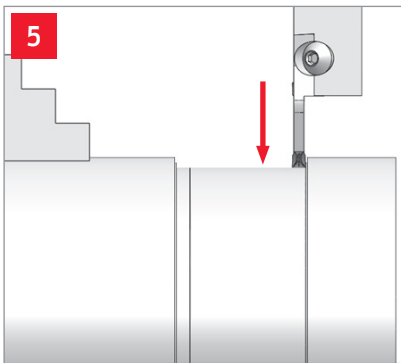

**5.** Plunge again from the far side of spindle, at the last retraction point.

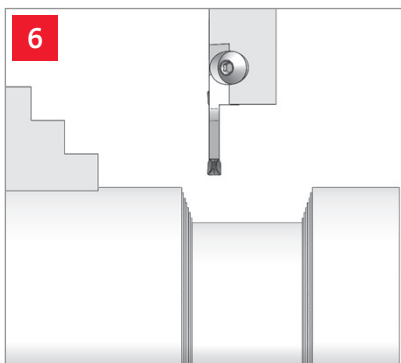

**6.** Repeat previous points until reaching full depth. Leave approximately 0,4 mm of stock, to be removed during the finishing operation.

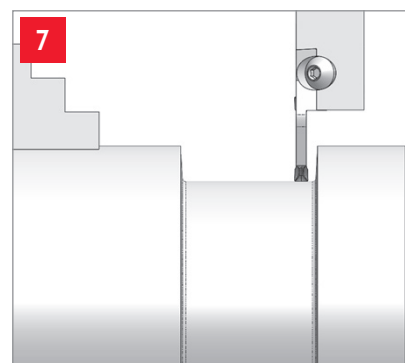
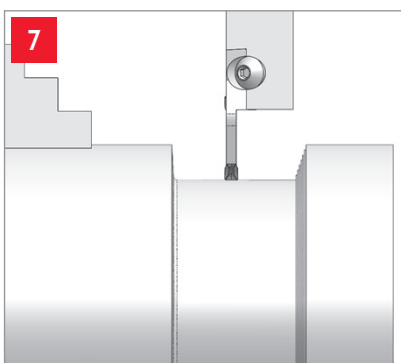

**7.** These roughing strategy should be complemented by a dedicated finishing pass (see page 31).

## ROUGHING - GROOVE PLUNGING

### Use multiple plunges:

Leave narrow walls between cuts to be removed at the end.

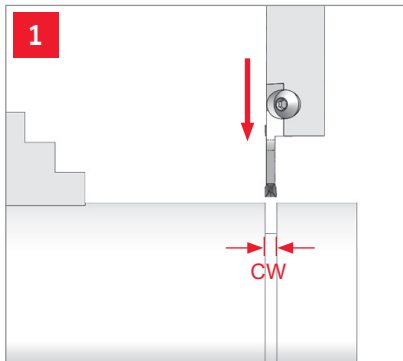
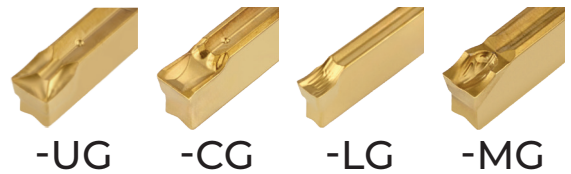

**1.** Start radial entry from the farthest side of the spindle radius. Perform intermittent plunges toward the spindle, spacing narrow walls between each groove - this ensures chip flow and protects the corner radius.

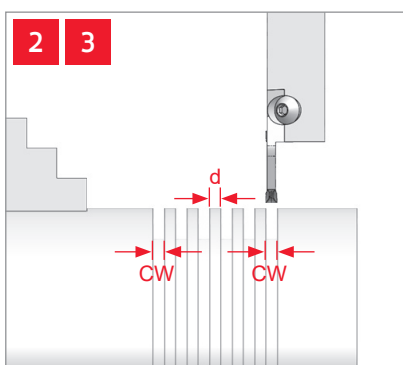

**2.** The first and last grooves should match the insert width (CW). Intermediate plunges (**d**) must leave walls of width = **CW - 2RE**.

**3.** Finish by removing the remaining walls for consistent geometry.

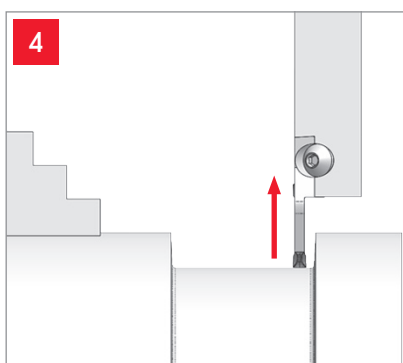

**4.** Retract radially again (~ 0,10 mm) after the turning pass to relieve the insert.

Leave approximately 0,4 mm stock to be removed during the finishing operation.

**Note:** These roughing strategy should be complemented by a dedicated finishing pass (see page 31).

## FINISHING OPERATION

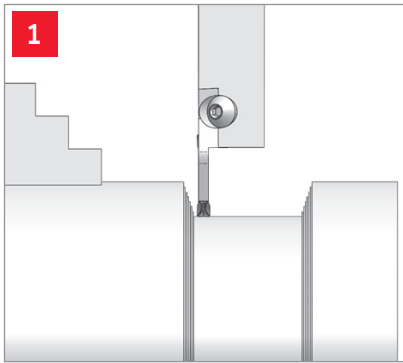

**1.** Access the pre-machined groove from the spindle side.

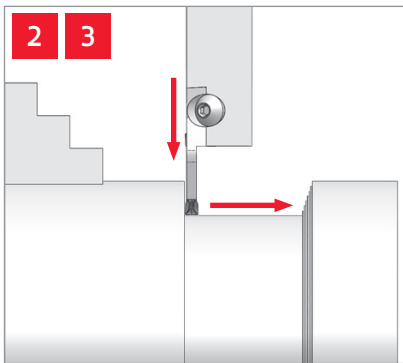

**2.** Retract and position the tool near the inner shoulder, close to the spindle.

**3.** Profile the desired radius by finishing the shoulder left from roughing.

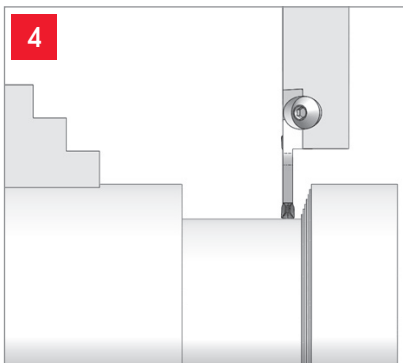

**4.** Perform a longitudinal turning pass along the bottom surface toward the opposite shoulder, then retract the tool.

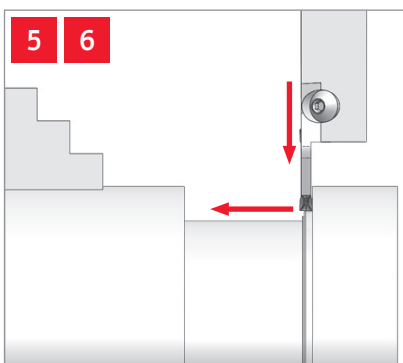

**5.** Re-enter the groove from the far side of the spindle.

**6.** Profile the second radius by finishing the far-side shoulder left during roughing.

## Apply the right method:

Select between single-pass, multi-pass or traverse strategies depending on groove width and depth to manage chip flow and protect the insert.

## PRE-MACHINING PRECAUTIONS

**Groove within holder range:** First groove must stay between the minimum and maximum diameters of modular or monoblock holders.

**Use the widest possible insert:** Improves rigidity and cutting stability.

**Modular setups:** Combine right-hand holders with left-hand cartridges and vice versa to ensure correct tool orientation in face grooving.

**Prefer continuous feed for long chips:** Enhances chip flow and prevents blockage.

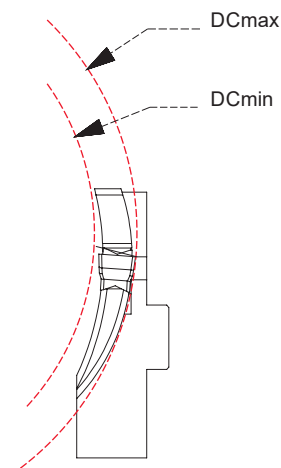

## STRATEGIES - INITIAL PASS

**Continuous feed:** Use reduced feed rate to generate longer chips that evacuate more easily and reduce insert wear.

**Interrupted feed:** If the chips are too long, apply short stepped advances to break longer chips into smaller segments and avoid jamming near the insert.

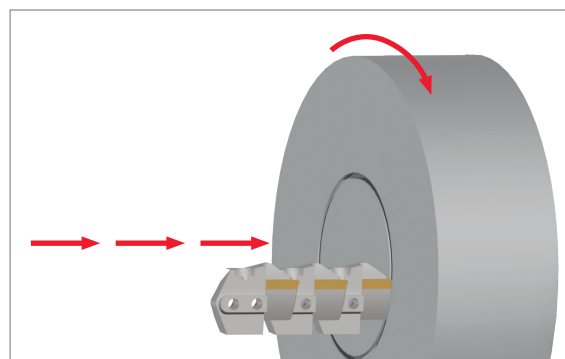
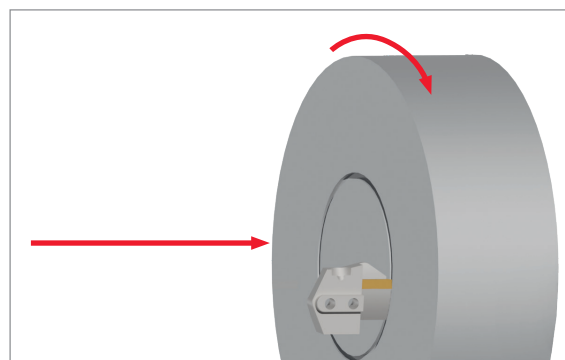

## PLUNGING IN MULTIPLE PASSES

### Initial Pass:

- Start from the largest diameter and plunge toward the bottom of the groove
- Retract the tool before indexing to the next plunge position

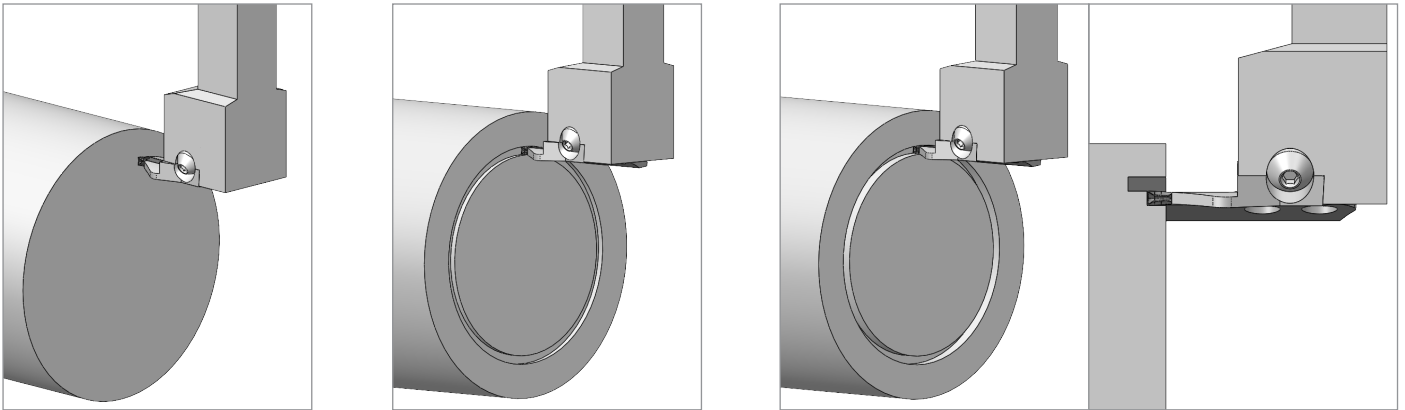

### Next Passes:

- Keep plunging radially inward using 60–80% of the insert width
- Increase feed by 30–50% for faster machining.
- Retract the tool before each new plunge
- Leave approximately 0,4 mm stock to be removed during the finishing operation

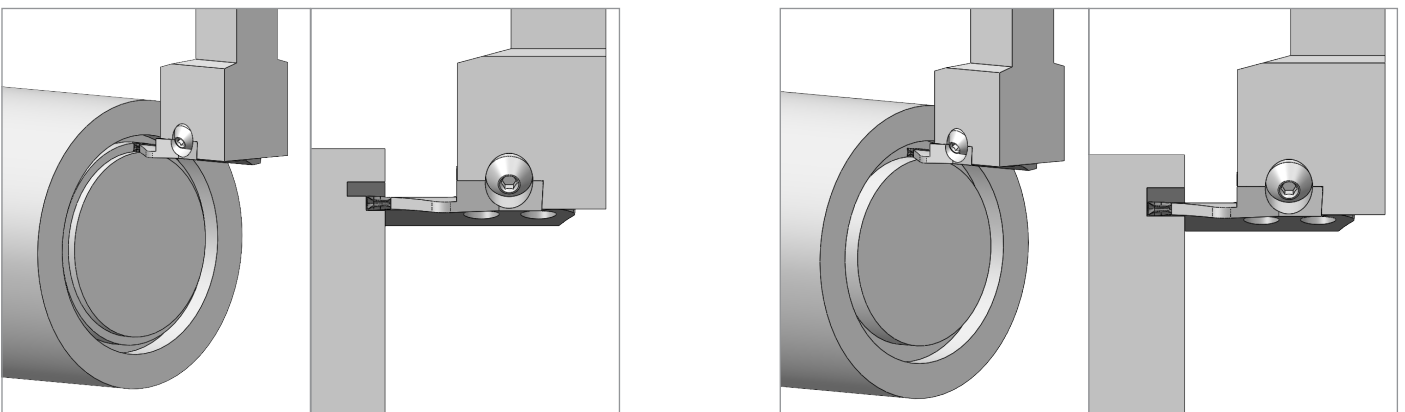

## PLUNGING AND FACE TURNING

### Initial Pass:

- Limit depth of cut to 40% of the insert width to ensure cutting stability
- Plunge radially from the outer diameter and begin side turning toward the centre
- Retract the tool after reaching the end of the pass

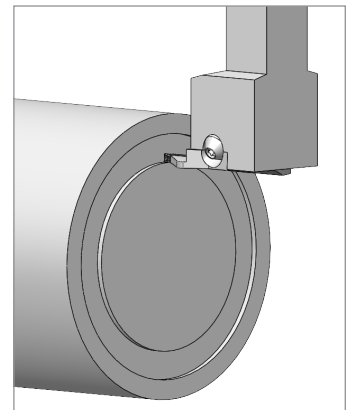
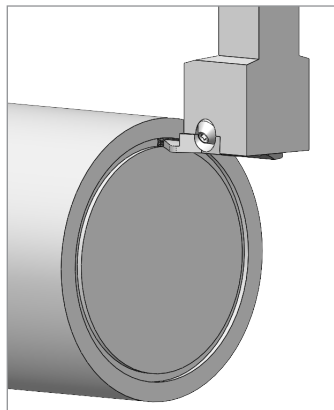
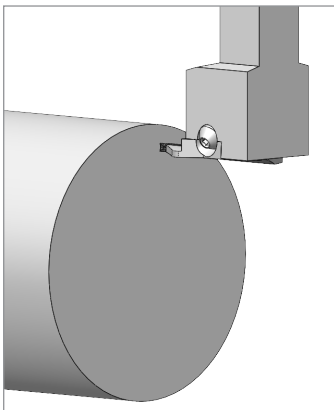

### Second Pass:

- Re-enter with a new plunge at the previous retraction point
- Perform side turning outward
- Avoid feeding into the shoulder created by the previous pass
- Retract the tool again

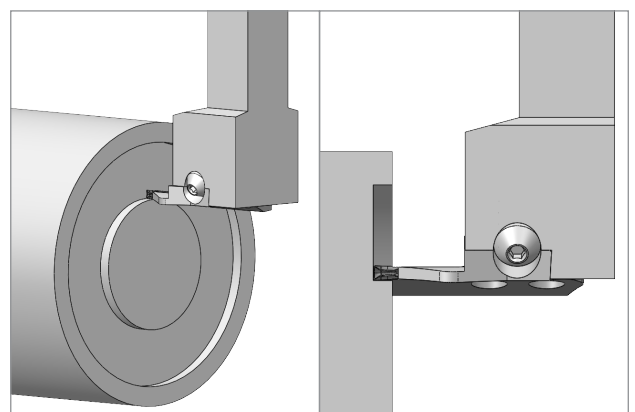
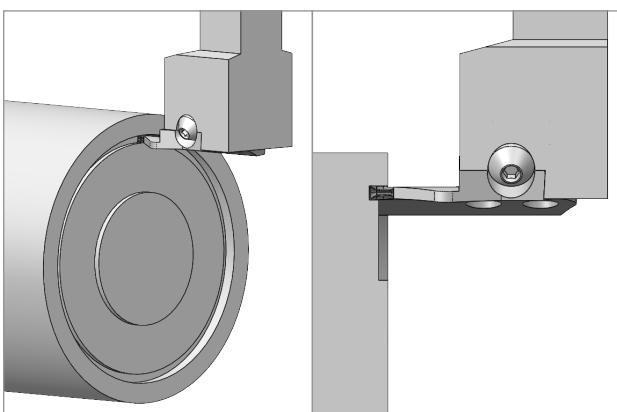

## PLUNGING AND FACE TURNING

### Next Passes:

- Repeat the plunge and traverse cycle, alternating directions
- Leave 0,2 mm between each pass to prevent shoulder overlap and improve chip control
- Leave approximately 0,4 mm stock to be removed during the finishing operation

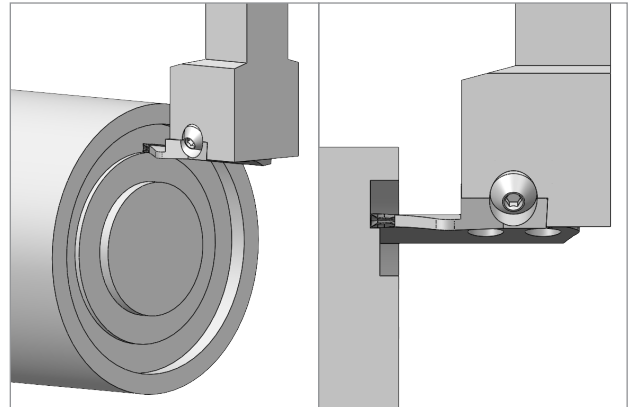
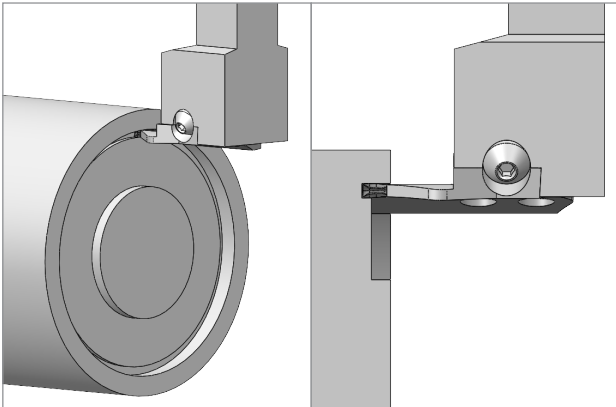

**Note:** Starting the traverse face cutting within the tool's effective diameter range ensures full access for widening the groove without diameter limitation.

## FINISHING

These roughing strategies should be complemented by a dedicated finishing pass.

- Perform the initial plunge adjacent to the outer diameter corner radius.
- Retract and reposition the tool to execute a profiling pass on the outer shoulder.
- Continue with a traverse cut along the groove bottom toward the inner shoulder, then retract the tool.
- Re-enter from the inner diameter side and finish the inner shoulder radius.

## TOOL SELECTION

### Medium Parting:

- For diameters below 40 mm
- Use two-edge inserts with monoblock holders for increased rigidity
- Keep the tool overhang as short as possible to avoid vibration

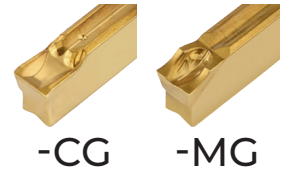

### Deep Parting:

- For diameters above 40 up to 124 mm
- Use single-edge inserts mounted on blade holders
- Keep overhang to a minimum to avoid vibration and insert breakage

## TOOL POSITIONING

### Tool Overhang:

- Keep the tool overhang as short as possible to reduce vibration and improve stability
- Always part off close to the chuck to minimize tool bending
- To maintain optimal operating conditions, minimize tool deflection, and maximize service life, it is recommended to limit the reach to 8-10 times the groove width.

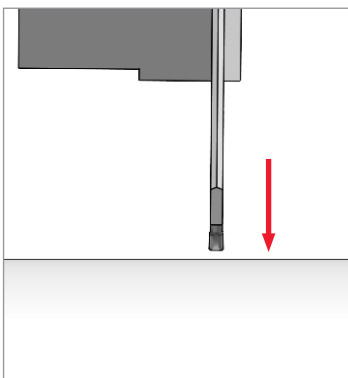

Recommended:

✗ exceeded 8-10 times the CW

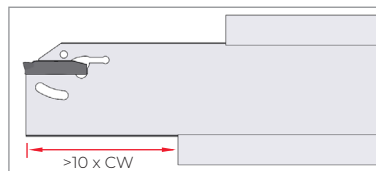

✓ did not exceed 8-10 times the CW

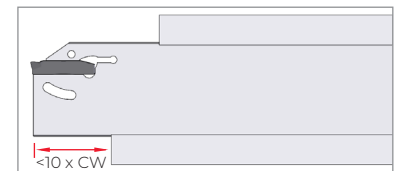

### Centering:

- Position the cutting edge in line with the center of the part, with a tolerance of  $\pm 0,1$  mm
- For long tool overhangs, set the cutting edge 0,1 mm above center to compensate for tool deflection

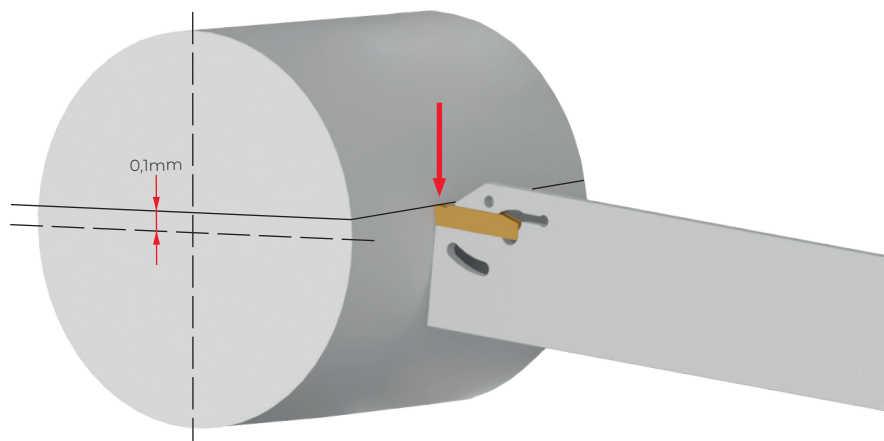

## FEED

- Reduce feed by 50–75% approximately 5 mm before reaching the center of the bar to minimize cutting forces
- Stop cutting 0,5 mm before center to let the part separate naturally and protect the insert

## RETRACTING TOOL

- After parting off, shift slightly in the axial direction before retracting the tool
- This relieves side pressure on the insert and helps prevent rubbing or vibration

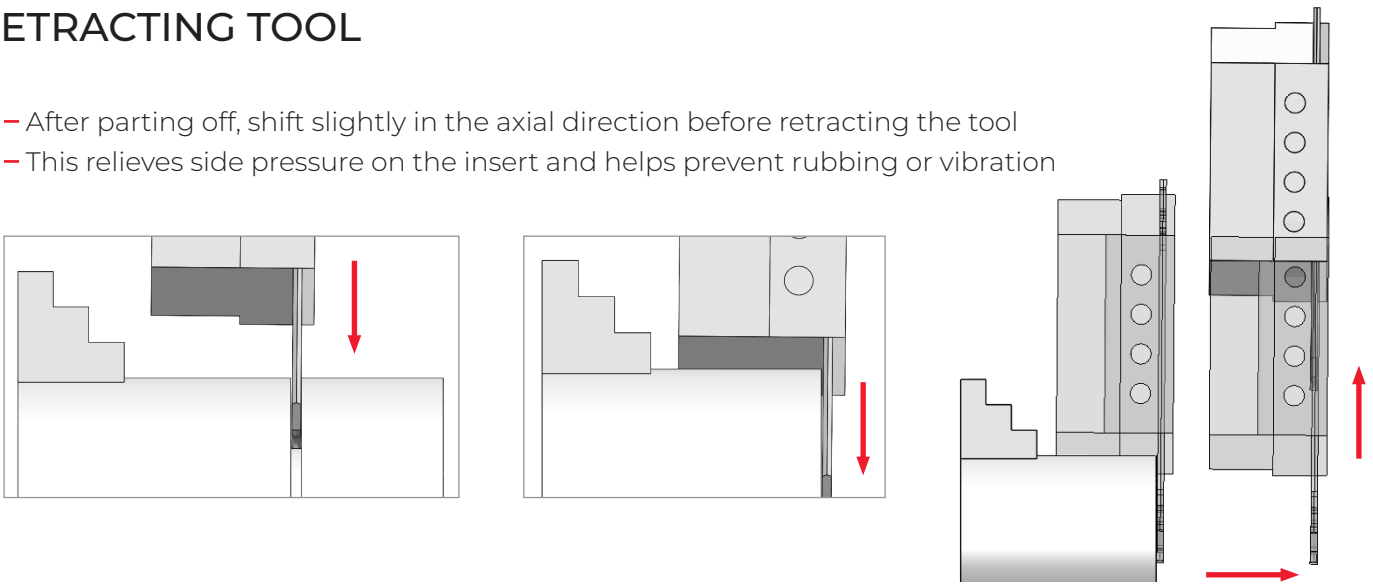

## INSERT

- Use the narrowest insert suitable for the application – Minimizes cutting forces and energy consumption
- Select the first recommended grade
- Use mid-range cutting conditions of the recommended speed and feed range for balanced tool life and performance
- We recommend an insert width of 2 mm for part diameters below 50 mm
- We recommend an insert width of 3 mm for part diameters above 50 mm
- Neutral cutting edge is recommended as the primary option
- For long overhangs, always use neutral inserts
- Use left- or right-hand front-angled inserts to reduce pips or burrs

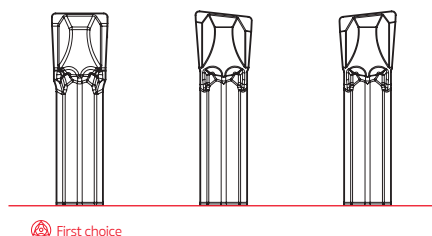

First choice

# MASTER GROOVING

Precision & versatility for grooving operations



Check the QrCode for more information



## HEADQUARTERS

PALBIT. S.A.

T (+351) 234 540 300 | F (+351) 234 540 301

palbit@palbit.pt | www.palbit.pt

## Branch office

PALBIT México, S de RL de CV

T (+52) 5555 454 543 | F (+52) 5552 509 190

info@palbit.com.mx | www.palbit.pt/mx

## Branch office

PALBIT Brasil

T (+55) 011 25 343 648

palbit@palbit.com.br | www.palbit.pt/br